



HAL
open science

Distributed Internet-based Performance Support Environment for Individualized Learning (DIPSEIL) – the Model

Nevena Mileva, Dimitar Tokmakov, Mihail Milev

► **To cite this version:**

Nevena Mileva, Dimitar Tokmakov, Mihail Milev. Distributed Internet-based Performance Support Environment for Individualized Learning (DIPSEIL) – the Model. Conference ICL2007, September 26 -28, 2007, 2007, Villach, Austria. 7 p. hal-00257114

HAL Id: hal-00257114

<https://telearn.hal.science/hal-00257114>

Submitted on 18 Feb 2008

HAL is a multi-disciplinary open access archive for the deposit and dissemination of scientific research documents, whether they are published or not. The documents may come from teaching and research institutions in France or abroad, or from public or private research centers.

L'archive ouverte pluridisciplinaire **HAL**, est destinée au dépôt et à la diffusion de documents scientifiques de niveau recherche, publiés ou non, émanant des établissements d'enseignement et de recherche français ou étrangers, des laboratoires publics ou privés.

Distributed Internet-based Performance Support Environment for Individualized Learning (DIPSEIL) – the Model¹

Nevena Mileva¹, Dimitar Tokmakov², Mihail Milev³

Plovdiv University¹, Plovdiv University², Plovdiv language school³

Key words: *Distributed learning management systems, performance-centred approach in education and training, individualized learning, eLearning*

Abstract:

Distributed Internet-based Performance Support Environment for Individualized Learning (DIPSEIL) is a project to define, develop and test a distributed system for individualized learning and the underlying pedagogical procedures to implement, facilitate and promote performance-centered learning experiences in the context of international university education. Using DIPSEIL Model we have developed the first prototype of DIPSEIL with two main characteristics: Distribution and Individualization. Distribution reflects mainly on the functionality and organization of the Editor – the system for the teachers. Individualization reflects on the way that the user will use DIPSEIL system – Student Area. DIPSEIL promotes the concept of distributed learning with an attempt to make a conceptual shift from a support of individual learning, based on information processing, towards a support of learning based on distributed cognition.

1 Introduction

1.1 The need

DIPSEIL is a project to define, develop and test a *distributed* system for *individualized* learning and the underlying pedagogical procedures to implement, facilitate and promote performance-centered learning experiences in the context of international university education. DIPSEIL is a continuing work, based on an existing model, developed working prototype, conducted empirical research and analysis of experimental data that have been done in a previous project – Internet-based performance support system with educational elements IPSS_EE (Minerva, 90213-2001).

The analysis of the existing theory and practice of applying the idea of performance support systems reveals that the provided solutions are short of exploring fully the advantages of Internet for managing distributed pedagogical resources. The soundest reason is that learning design embedded in these IPSS applications is based upon the principles of cognitive paradigm of individual information processing. This theoretical framework does not present adequate conceptual and operational means for providing relevant answers of the questions related to the distributed learning resources in the context of performance support systems. In order to address the issues identified in our experience of designing IPSS_EE and the

¹ Acknowledgement

The authors would like to acknowledge to the European Union Socrates the support in the Project 225692-CP-1-2005-1-BG-MINERVA-M “DIPSEIL – Distributed Internet-based Performance Support Environment for Individualized Learning”

problems reported in current practice of applying IPSS solutions, this project promotes the concept of distributed learning with an attempt to make a conceptual shift from a support of individual learning, based on information processing, towards a support of learning based on distributed cognition.

1.2 The background

Under IPSS_EE project we developed IPSS_EE Model that provides: main steps and activities that the course designer has to undertake preparing the course, presented and structured as IPSS_EE, and obtained results from these activities; structure and information flow of teachers' and students' environments; administration principles, methods and interface specification, and organization of centralized IPSS_EE data-base. We designed and developed the IPSS_EE prototype and task-oriented training modules for different engineering courses. The main aspects of the research were related to: pedagogic effectiveness of the student centered task-performance oriented learning; the change in educational mission from instruction to the provision of methods for personal learning; the transition from objective to constructive knowledge. After experimental design we conducted pilot test with small groups of students, and larger groups of students from engineering specialties in the field trial. The data analysis proves the pedagogic effectiveness of performance-centered method of learning as indicated by performance, attitudes and perceptions of students.

In our partnership experience in designing, developing, evaluating and implementing IPSS_EE and eLearning practice, we indicated a number of needs and problems:

- technological problems caused by *centralized IPSS_EE data-base* that we have pointed before;
- lack of operational definition, functional specifications and development solutions of distributed learning in relation to performance support concept – *distributed performance-centered learning*;
- need for *validation* of distributed performance-centered instructions within different subjects and different educational systems;
- the growing need for *individualized learning* - an overview of the current practice of IPSSs, including IPSS_EE, reveals that most of the performance-centered applications do not address sufficiently this need.

In this course, DIPSEIL project presents a possibility for:

- elaboration of IPSS_EE Model to Distributed Internet-based Performance Support System (DIPSS) Model;
- definition theoretical construct and development of Adaptive System Model (ASM);
- DIPSS and ASM integration in the DIPSEIL framework;
- validation of distributed performance-centered individualized learning methods within multi-language and multi-subject educational systems by qualitative evaluation and quasi-experimental groups design, to confirm the pedagogical effectiveness of DIPSEIL with larger and more groups, on that already confirm with IPSS_EE.

2 Individualization in DIPSEIL – Adaptive System Model (ASM)

There is a wide range of individualization techniques has been introduced based on data about a user. One of the techniques is based mostly on adapting navigation, content selection and presentation according to the user's selection and performance in a particular domain. The performance is often evaluated in a small closed domain, e.g. an electronic course at the university. These techniques are usually called Adaptive hypermedia techniques.

IPSS_EE Tasks for performance are suitable for individualization. Individualized access means that resources are used according to some relevant aspects of the user. In DIPSEIL context it is important to take into account aspects like whether the user is student or a teacher, whether he wants to obtain a certain qualification, or gain specific skills and knowledge, has specific preferences, and, of course, which is his knowledge level for the selected topics.

We annotate each Task for performance by the topics covered in this task. We provide one attribute (*aims_work_name*) for annotating resources with the specific topic. We enable students to select tasks from IPSS_EE data-base, using this attribute to generate data-base structural tree on the screen.

Specifying the level of skills and knowledge, we create the user profile. Then we query for appropriate resources, directly mapping and comparing what we have in the user profile and what we have in tasks' description. It also means that we assign the learning resource to the created user profile required for accessing this learning object. We use Capability Adviser (CA) (<http://www.dipseil.net> link Environment, Student Area, Capability Adviser) to create the user profile: the skills of students are assessed, already gained skills are recognized, and only for the skill gaps a learning plan is established. The learning plan, among the other learning possibilities, provides access to the specific learning resources, according to the student's profile.

We present ASM using four different scenarios:

IPSS_EE_LO will be created, or edit, if the user is a teacher. IPSS_EE Tasks for performance will be performed, if the user is a student.

IPSS_EE Tasks for performance will be used by the user, who is learning associated to this task subject, and have "Not applicable" knowledge and skills about the topic.

IPSS_EE Task for performance will be used by the user, who is interested in this topic.

Package of IPSS_EE Tasks for performance, in form of IPSS_EE, will be used by the user, who wants to obtain a certain qualification.

3 Distributed Internet-based Performance Support System Model (DIPSS Model)

DIPSS Model defines the technical foundations of DIPSEIL. It is a model that references a set of interrelated parts, specifications and guidelines designed to meet the requirements for distribution and personalization. DIPSS Model aggregates IPSS_EE Tasks for performance in IPSS_EE Environment to support adaptive instruction based on learner objectives, preferences, performance and other factors (like performance-support instructional techniques). IPSS_EE, as a typical performance support system, is an integrated electronic environment, which is available via Internet and is structured to provide individualized online access to the full range of information, guidance, advice, data, images, tools and software to permit the user to perform a task with a minimum of support and intervention by others. IPSS_EE has two specific characteristics: the learning content is presented as "tasks for performance" that aim preliminary specified learning outcomes. The aggregation of IPSS_EE Tasks for performance and IPSS_EE Environment presents the content launch process, communication between content and IPSS_EE Student Area (www.dipseil.net), and standardized data model elements used for passing information about the learner.

DIPSS Model also describes Sequencing and Navigation (S&N) Model for the dynamic presentation and editing of learning content based on user needs. S&N Model describes how IPSS_EE Tasks for performance may be sequenced through a set of learner-initiated or system-initiated navigation events. The branching and flow of that content may be described by a predefined set of activities. It describes the branching and flow of learning activities in terms of Learner’s Activity Flowchart (LAF), based on the results of a learner’s interactions with content objects and the sequencing strategy. LAF is a conceptual structure of learning activities managed by DIPSEIL for each learner as shown:

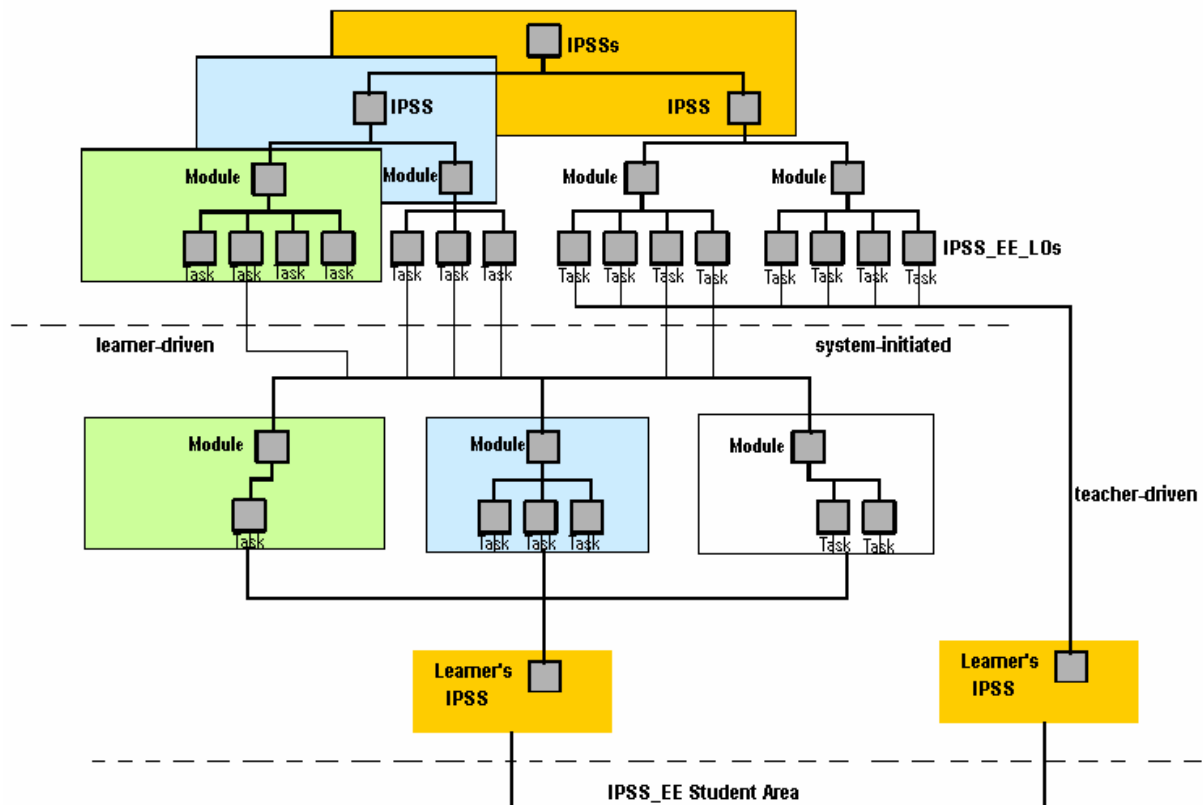

LAF shows how **learner-initiated** and **system-initiated** navigation events can be triggered and processed, resulting in the identification of learning activities for delivery. Learner-initiated navigation events are teacher-driven, when the IPSS_EE is a subject for certification, or learner-driven, when IPSS_EE is created according to the student’s preferences. Each learning activity identified for delivery will have an associated content object. LAF describes how identified content objects are launched. The sequence of launched content objects for a given learner and content structure provides a learning experience (learner interaction with content objects). IPSS_EE Student Area manages the resulting learning experience (Learner’s IPSS).

4 Distributed Internet-based Performance Support System (DIPSS) Architecture

Distributed Internet-based Performance Support Environment for Individualized Learning is defined as an integrated and Internet accessible collection of performance support systems for educational purposes, that can be used when required, at a particular point of need, by an individual user, or a workgroup. In DIPSS Architecture, multiple users can interact with distributed educational content in real time, running on several servers, connected by a computer network using client server applications.

DIPSS Architecture consist one or more local IPSS_EE servers with the corresponding server side software, connected with a communication server, via Internet. Communication Server software provides services for allocation of educational resources, creating database repository and course (IPSS_EEs) management.

The main characteristics of DIPSS Architecture:

- The local IPSS_EE servers are independent of one another. They contain IPSS_EE Tasks for performance packages for various scientific subjects.
- The local IPSS_EE servers are geographically allocated and language specified.
- The learning objects repository and database of IPSS_EE are maintained on the communication server by replication of the databases and content files of local servers.
- The distributing environment for the databases replication and content files is Internet. The operational systems of the local IPSS_EE servers are heterorganic (Linux, Solaris, Windows and others).
- Replication and communication system, for content retrieval, login service, student records exchange service, IPSS_EE skill assessment portal and test manager, realized as web services, runs on the communication server.
- The replication system, synchronization and transfer of files and learning objects are completely automatic. The communication server software is platform independent.

5 Conclusions

Using DIPSS we have developed the first prototype of DIPSEIL with two main characteristics: Distribution (DE) and Individualization (IE). Distribution reflects mainly on the functionality and organization of the Editor (www.dipseil.net link Environment, Editor) – the system for the teachers. We evaluate the distribution in the process of development and completion DIPSEIL data-base. This evaluation is different from the experts' evaluation during the design and development of first and second prototypes. Individualization reflects on the way that the user will use DIPSEIL system – Student Area (www.dipseil.net link Environment, Student Area).

Main evaluation assumptions in our pilot experiments are:

DE.1 It is more easy and comfortable to access the DIPSEIL data-base – less problems with the language, speed etc.

DE.2 It is possible to organize different IPSS_EE Tasks for performance, from different servers, in different languages, on different subjects, in IPSS_EE specific interface

DE.3 The content of different subjects is possible to organize as IPSS_EE Tasks for performance with defined parameters (look at DIPSS Model)

IE.1 The DIPSEIL (Student Area) answers to the students' expectations for freedom, preferences, level of skills and knowledge

IE.2 Two types of learners – activists and reflectors, find their learning paths in DIPSEIL

References

- [1] GERY, G. (2002). Performance support – driving change. In A. Rossett (Ed.), *The ASTD e-learning handbook. Best practices, strategies, and case studies for an emerging field* New York: McGraw Hill. (pp. 24-37).
- [2] GREENBERG, J., & DICKELMAN, G. (2002). Distributed cognition: a foundation for performance support. In A. Rossett (Ed.), *The ASTD e-learning handbook. Best practices, strategies, and case studies for an emerging field* New York: McGraw-Hill. (pp. 303-313).
- [3] RAYBOULD, B. (2002). Building performance centered web-based systems, information systems, and knowledge management systems in the 21st century. In A. Rossett (Ed.), *The ASTD e-learning handbook. Best practices, strategies, and case studies for an emerging field* New York: McGraw-

Hill. (pp. 338-353).

- [4] ANDERSON, J. (1983). *The architecture of cognition*. Harvard: Harvard University Press
- QUILLIAN, M. (1988). Semantic memory. In A. Collins & E. Smith (Eds.), *Reading in cognitive science. A Perspective from psychology and artificial intelligence* San Mateo: Morgan Kaufman Publishers. (pp. 80-101).
- [5] RUMELHART, D, & MCLELLAND, J. (Eds). (1986). *Parallel distributed processing: Exploration in microstructure of cognition: Vol. I Foundations*. Cambridge: MIT Press.

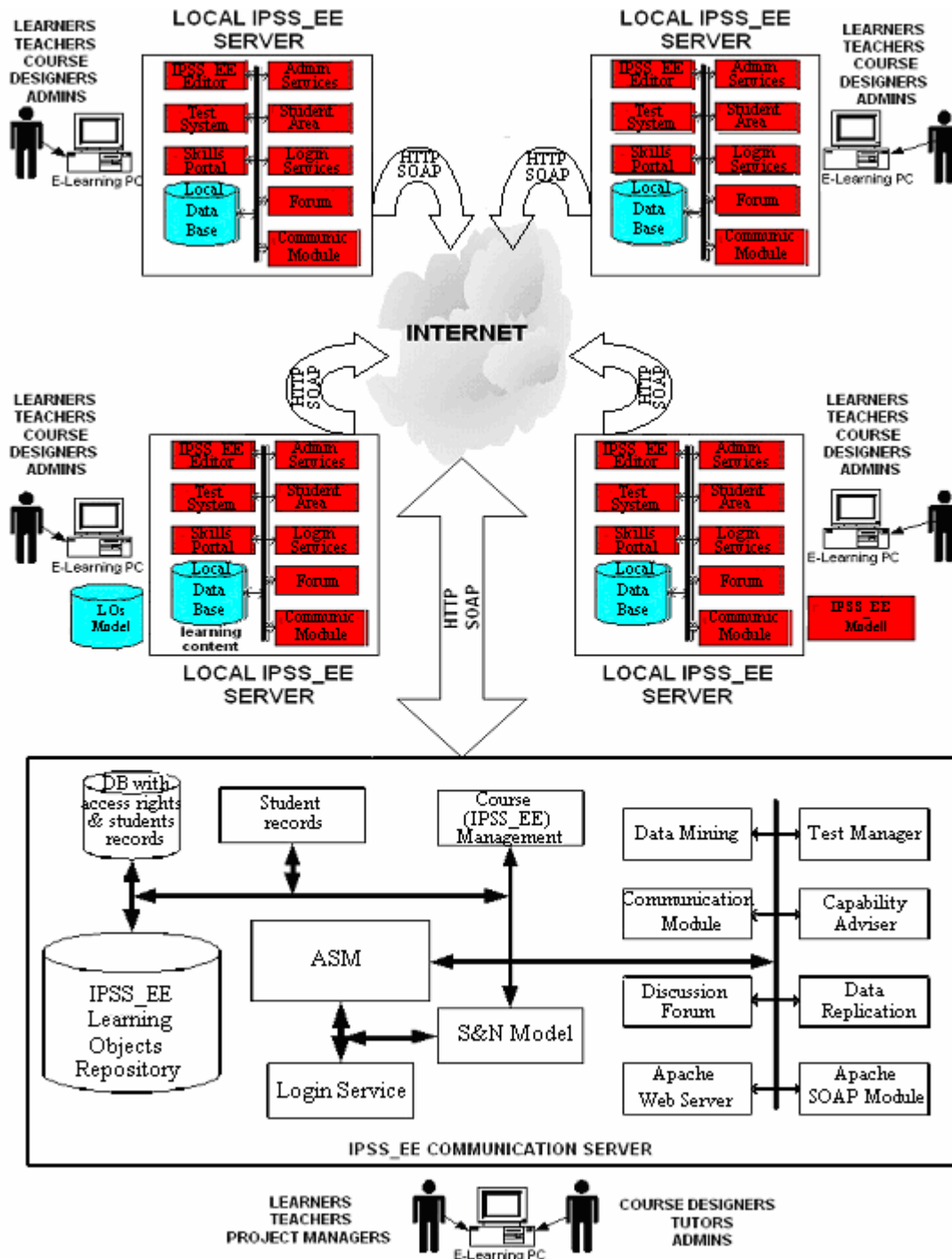

Author(s):

Nevena, Mileva, Professor
 Plovdiv University, ECIT Department

24 Tzar Assen, 4000 Plovdiv, Bulgaria
nmileva@pu.acad.bg

Dimitar, Tokmakov, Assistant-professor
Plovdiv University, ECIT Department
24 Tzar Assen, 4000 Plovdiv, Bulgaria
tokmakov@pu.acad.bg

Mihail, Milev, Student
Plovdiv Language School
mihailsmilev@gmail.com