

PRAXIS:

Pervasive Rehabilitation of Aphasia with
an eXtensible Interactive System
Phase I: Design

Kiernan Burke

Master of Science in Interaction Design

Interaction Design Centre
Department of Computer Science &
Information Systems
University of Limerick
Limerick, Ireland

Supervisors: Mikael Fernström, Sue Franklin

Submitted to the University of Limerick, August 2007

DECLARATION

Project: Pervasive Rehabilitation of Aphasia with an eXtensible Interactive System: Phase I (PRAXIS)

Supervisors: Mr. Mikael Fernström, Professor Sue Franklin

This project is presented in partial fulfillment of the requirements for the Master of Science in Interactive Media. It is entirely my own work and has not been submitted to any other university or higher education institution, or for any other academic award in this university. Where use has been made of the work of other people, it has been fully acknowledged and fully referenced.

Kiernan Burke

Date:

ABSTRACT

PRAXIS: Pervasive Rehabilitation of Aphasia with
an eXtensible Interactive System (Phase I)

Kiernan Burke

This thesis describes computer-assisted (CA) methods for the treatment of acquired language impairment in adult aphasics. A key design objective of this project was the elimination of the indirect manipulation of keyboard and mouse (in CA speech language therapy sessions) in favour of the direct manipulation of virtual and physical objects afforded by touchscreen display and radio frequency identification technology (RFID).

While computer-assisted treatment of aphasia has been used since the 1960s, the efficacy and effectiveness of such treatment is inconclusive. Contradictory results exist in textbooks and research studies. This work seeks to add to the debate with the development of methods that may or may not offer greater stimulus to patient-users and which may, or may not, result in improved rehabilitation of language impairment.

The text begins with an overview of aphasia and aphasiology, and speech language therapy. Theory and practice as described in readings both within the aforementioned subjects and in the areas of human-computer interaction and accessible computing, and informal interviews with an expert in the field of aphasia are discussed in the following section on system design. Guidelines for design requirements are drawn therefrom. Where a specific consideration led to a requirement it is set forth in the relevant section.

Functional description of hardware and software elements of the system follow, and are in turn followed by a description of prototype evaluation, and perceived limitations of the system.

Future development (Phase II) of the system may include back-end services for direct and Web data acquisition with a view to clinical-outcome research.

DEDICATION

To my partner Helena: For your constant and continuing love, encouragement and support, my love and thanks.

ACKNOWLEDGEMENTS

In this Era of Information, the researcher who delves into an interdisciplinary pursuit owes thanks to literally thousands of individuals and organizations. While it is obviously impossible to mention so many individuals, I am mindful of, among others, the work of computer scientists, hardware and software developers, of psychologists, neurologists, aphasiologists, of medical researchers, and social scientists, in particular, those who seek to define the needs of the disabled, and to reevaluate our attitudes and perception of disability.

I extend my gratitude to the following individuals:

To Mr. Mikael Fernström, my supervisor and course director, for his generosity, encouragement, and boundless enthusiasm, Professor Sue Franklin, for her joy, encouragement, and guidance and Annette Aboulafia, for her enthusiasm, humour, and willingness to referee my continuing work.

To Professor Liam Bannon, for his observations on human-computer interaction that helped me think outside the box, and Kate Boulay and Joe Griffin whose excellent lectures helped extend the boundaries of the box.

To Luigina Ciolfi, for her enthusiasm, and for raising the bar on intellectual rigour, Paul Gallagher and Marc McLoughlin for help with C++ driver code and ActionScript, and Anne Murphy for keeping the whole show running.

Acknowledgement is made to Macromedia (now Adobe) developers Dan Carr and Andrew Cheney. Portions of their “learning interactions” code were used and modified.

And lastly, to the Government of Ireland and the European Union, whose social and educational policies affirm and support affordable education and lifelong learning.

FOREWORD

codifiable information.
all information:
codified:

from the time of script
and to be,
by the network scribes:
laptop desktop wireless and wired.

all information:
with or without merit which began as,
and will now exist in perpetuity as:
digital artefact.

and instant and infinite
and instant and infinite
and instant and infinite ...n
of it all
is:

a gathering:
knowledge and access,
gathering force,
collective voice.

but all this without
the act and art
of lascaux, rosetta, kells?

that is:

the hand on
rock to clay
chisel to stone
pen to paper.

CONTENTS

DECLARATION	ii
ABSTRACT	iii
DEDICATION	iv
ACKNOWLEDGEMENTS.....	v
FOREWORD	vi
CONTENTS	vii
LIST OF FIGURES.....	x
LIST OF TABLES.....	xi
1 Introduction	12
1.1 Stroke	12
1.2 Aphasia and Aphasiology	2
2 Establishing Design Requirements.....	6
2.1 Introduction.....	6
2.2 Requirements based on user needs assessment.....	6
2.2.1 Patient	7
2.2.2 Therapist	7
2.2.3 Caregiver-stakeholder	8
2.3 Requirements based on specific impairments.....	8
2.3.1 Visual impairment.....	9
2.3.2 Comprehension impairment.....	9
2.3.3 Motor impairment	9
2.4 Requirements based on readings in aphasiology and neurophysiology.....	9
2.4.1 Attention	10
2.4.2 Visual Cueing.....	10
2.4.2.1 Enhanced detection	11

2.4.2.2	Phonological and semantic cueing.....	12
2.4.3	Requirements based on clinical practice.....	12
3	System Design.....	13
3.1	Hardware.....	13
3.1.1	Computer.....	13
3.1.2	Keyboard.....	14
3.1.3	Display.....	15
3.1.3.1	Type.....	15
3.1.3.2	Screen size.....	16
3.1.3.3	Screen height and orientation.....	17
3.1.3.4	Wacom Cintiq.....	19
3.1.4	RFID Hardware.....	20
3.1.4.1	Introductory remarks.....	20
3.1.4.2	Texas Instruments Tag-It 6000 RFID.....	21
3.1.4.3	Handling RFID Connections.....	23
3.2	Software.....	24
3.2.1	Overview.....	24
3.2.2	Establishing Software Requirements.....	25
3.2.3	RFID Interaction.....	26
3.2.4	Touchscreen interactions.....	27
3.2.4.1	Lessons learned during the design process.....	27
3.2.4.2	Screen design.....	29
3.2.4.3	Description of interactions for word finding with interactive display.....	30
4	Summary of system requirements.....	32
4.1	User requirements.....	32
4.2	Hardware requirements.....	32
4.3	Interface requirements.....	33
5	Scenarios.....	33

5.1.1	Local connection.....	33
5.1.2	Remote.....	35
5.1.3	Therapist/ researcher interaction.....	35
6	Evaluations	36
6.1	Conclusions.....	38
7	Conclusions, Limitations, Future Work	38
	References.....	40

LIST OF FIGURES

Figure 1: Left hemisphere, language processing centres	3
Figure 2: ‘Wernicke-Lichtheim house’	3
Figure 3: Information-processing model of single word reading and writing	5
Figure 4: Enhanced detection by cueing	11
Figure 5: Layer model of abstraction in human-computer interaction	15
Figure 6: Gulfs of execution and evaluation	16
Figure 7: Two users interacting with touch screen (17”)	17
Figure 8: Horizontal line and line-of-sight.	19
Figure 9: Wacom Cintiq 21UX	20
Figure 10: Texas Instruments RFID tag	21
Figure 11: RFID Tag and Reader Operation	22
Figure 12: Formula for resonant frequency of a tank circuit.	23
Figure 13: Texas Instruments Tag-It Reader 6000	23
Figure 14: Connecting RFID reader to PC and Mac	24
Figure 15: RFID Interaction Flowchart	27
Figure 16: 1st and 2nd iterations of picture-word matching exercise	28
Figure 17: 3rd and 4th iterations of picture-word matching exercise	29
Figure 18: Word-picture match error	30
Figure 19: Fill-in Interaction	31
Figure 20: Element identification interaction	31
Figure 21: Rhyming pair matching	32
Figure 22: Single computer, 2 displays	34
Figure 23: Shuttle connections	34
Figure 24: PRAXIS world.	35
Figure 25: Triggering lexemes with images.	37

LIST OF TABLES

Table 1: Perceived benefit assessment.....	7
Table 2: Levels and types of attention	10
Table 3: Software program requirements	26
Table 4: Issues emerging from evaluations	36

1 Introduction

“The basic idea is that people don’t want to interact with computers. People want to get something done.”

Terry Winograd

“ In a fair society all individuals would have equal opportunity to participate in, or benefit from, the use of computer resources regardless of race, sex, religion, age, disability, national origin or other such similar factors.”

ACM Code of Ethics

The reader may ask why this thesis presents information on aphasia and user needs in a wider social context, when the principal work of this project is the design and implementation of a technological system. It is our belief that applied design which focuses first on technical features subordinates human needs to the computer. While it can be argued that user-centred design is now an accepted standard within the area of human-computer interaction we would ask whether the development of new technologies serves an existing need or creates new ones?

In defence of an approach that strays from the technocentric, we quote from the essay “Aphasia Treatment and Computer Technology”:

“Experience has also demonstrated that programmers who program with only limited understanding of treatment principles tend to produce treatment software that is limited in its effectiveness.”

Katz in Code & Müller (2002)

1.1 Stroke

Stroke is the third-leading cause of death in Western Europe and the United States, and the leading cause of serious disability. An estimated 150,000 accidents occur annually in the UK – an average of one stroke every 5 minutes. The majority of those affected by stroke are aged 65 or older. Stroke or cerebrovascular accident (CVA) occurs either as a disruption of blood flow to the brain (ischaemic), or when one or more blood vessels burst inside the brain (haemorrhagic). Ischaemic stroke may be caused by a blood clot that forms in a main artery of the brain (thrombus), a blood clot, fat globule or air bubble that is carried in the bloodstream to the brain (embolism), or blockage within small blood vessels of the brain (lacunar stroke). Haemorrhagic stroke is caused when a blood vessel bursts within the brain (intercerebral), or when a blood vessel on the surface of the brain bleeds into the space between the brain and skull (subarachnoid).

1.2 Aphasia and Aphasiology

Due to the localized organization of functions in the human brain, damage to one area of the brain can result in impairment or loss of one function while other functions remain intact (dissociation). For the majority of humans, language function is located in the left hemisphere. A lesion which affects these areas of the brain is known as aphasia (without speech). While estimates of the incidence of aphasia vary, the majority of studies reviewed put the figure at approximately one-third.

Aphasiology is the study of this impairment. The subject is complex, the history is rich and the literature is vast. An extensive discussion is beyond the scope of this proposal. Four main types will be described briefly within the context of their derived models: aphasias based on classical and neo-classical models, anomia, and the relatively recent model developed within the discipline of cognitive neuropsychology.

Conceptual models drawn from observations of aphasic syndromes date from the 18th century. In 1861, the French physician, Paul Broca, suggested that an area of the 3rd frontal convolution of the left frontal lobe was the centre for articulate language. He based his observations on an autopsy of the 57-year-old patient Leborgne, who had been virtually mute for 21 years, and was only capable of uttering the single word 'tan'. This area of the brain has subsequently become known as 'Broca's area' and is one of two cornerstones of the so-called classical models of aphasiology.

Carl Wernicke identified the second area of the brain that involves language processing in 1874. Wernicke attributed impairment in the comprehension of spoken language to damage to the posterior two-thirds of the superior temporal lobe. Damage in this area of the brain results in paraphasia, or sound production errors. But fluency of speech is retained, in contrast to the non-fluency that results from damage to Broca's area. This area of the brain has become known as 'Wernicke's area'.

A diagram of the left hemisphere of the brain, indicating these two language-processing areas of the brain follows (Source: Code, 1991):

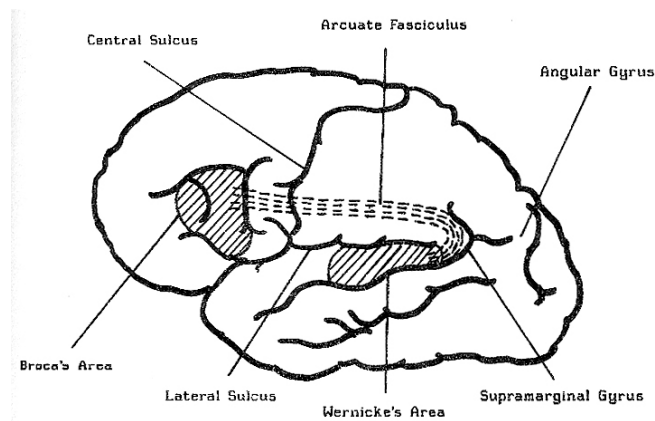

Figure 1: Left hemisphere, language processing centres

Wernicke subsequently described a model that encompassed Wernicke's and Broca's areas in terms of the expressive nonfluent form of aphasia observed by Broca, and the fluent form observed by Broca.

In 1885, the physician Ludwig Lichtheim proposed a more complex model based on Wernicke's. The following schematic is known as the 'Wernicke-Lichtheim house. (Source: Code, 1991)

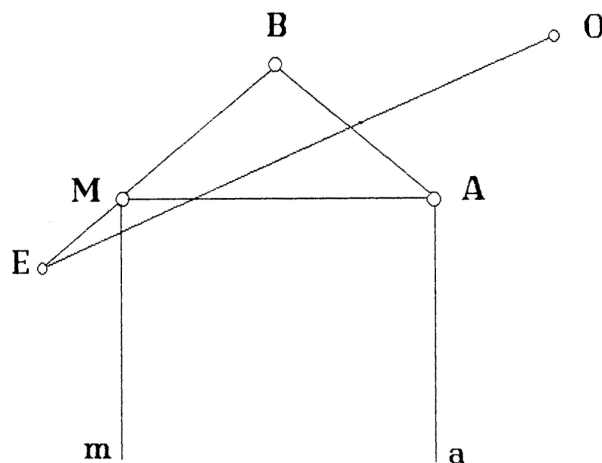

Figure 2: 'Wernicke-Lichtheim house'

'A', 'M' and 'B' represent Wernicke's area (auditory images), Broca's area (motor images), and the area of conceptualisation, respectively. 'E' and 'O' represent the motor writing and visual representation (reading) areas respectively. 'm' and 'a' represent the peripheral speech organs and primary auditory area respectively.

Damage to 'M' produces Broca's aphasia, which results in a loss of the abilities to speak, write, repeat, and read aloud or to take written dictation. Damage to 'A' produces Wernicke's aphasia leads to paraphasia, impairment in the comprehension of written and spoken language, reading aloud, and similar in nature to Broca's aphasia, the ability to read aloud, to repeat, or to take written dictation. A third type of aphasia, termed Conduction aphasia, occurs when there is damage to the pathway connecting Broca's and Wernicke's areas. In this type of aphasia, the affected activities are repetition, reading aloud, and writing to dictation. Written and aural comprehension, speech and writing are largely intact. A fourth type occurs when there is interruption to the pathway between Broca's area ('M') and the conceptual area ('B').

Concurrent with the classical model, a model based on a neurological representation of the nervous system was proposed by the English neurologist John Hughlings Jackson in 1866. With recent developments in neural imaging, Jackson's ideas still retain currency. In recent years, Jason Brown has carried Jackson's ideas further with his microgenic (i.e., perceptual or conceptual actions occurring within very short periods) model of aphasia. Brown and Jackson base their models on the evolution of language as manifest in the increasing complexity of the brain both as it is constituted in the human organism, and as it has developed during the course of evolution. Hierarchical organization underpins the neurological model.

In the mid-1960s, Norman Geschwind's disconnection model re-established links to Broca, Wernicke and Lichtheim's seminal work in its emphasis on damage to centres or pathways between centres as defining the prevalent form of aphasia experienced by the stroke patient. The chief assertion or reassertion of this model is that the anterior half of the brain governs motor activity, while the posterior area controls sensory activity. Subsumed in this disconnection model is the other major type of aphasia, Anomia. Anomia is characterised by the inability to find or remember words. The anomic lexicon is devoid of the substantive parts like nouns and verbs. Speech, grammar and comprehension are unaffected. While all aphasic persons have some form of word naming or finding difficulty, those with Anomia possess normal language processing skills in all other respects.

Naming is the fundamental act of language for Geschwind. The inferior parietal lobe is unique to the human species and it is the locus of other aspects of language development. The lesion responsible for anomia occurs in this area, in the supramarginal and angular gyri (cf.

Figure 1).

The approach of cognitive neuropsychology represents a paradigm shift in thinking about the subject of aphasia and theories of aphasia. In this approach, an information-processing model is employed. As it is accepted that no two cases of aphasia are identical, cognitivists argue that the traditional investigative model-based method of categorization of symptomatic groupings is obsolete. Some researchers have suggested that there may be thousands of different forms of aphasia. Cognitive psychologists argue therefore, that classical models should give way to a theoretical approach. It is argued that the neural structures employed in language differ from motor and sensory activity, and that the psychological operations involved in speech are unconscious processes unique to language.

The core framework of the cognitive neuropsychological approach to aphasia is the information-processing model. An example of this model, which depicts the processes involved in the reading and writing of single words, is shown below. It is the view of cognitive neuropsychologists that processes involving cognitive acts such as language, facial recognition, and memory function in a modular manner, and are independent of other cognitive processes (Source: Code, 1991)

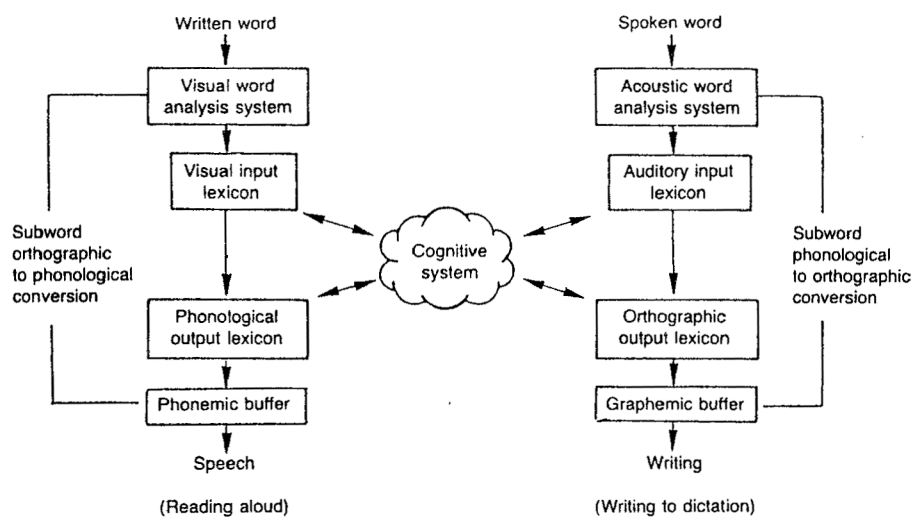

Figure 3: Information-processing model of single word reading and writing

Evidence for an underlying modular structure is based on a range of individual cases. The cases used to provide this evidence are very rare however. For example, there are cases where anomia is limited to specific categories such as fruit or vegetables. The existence of discrete

semantic categories that exist in memory (e.g., anomia involving specific categories of words such as fruit and vegetables) are considered proof of an underlying modular structure.

2 Establishing Design Requirements

2.1 Introduction

"Interaction design is designing interactive products to support people in their everyday and working lives."

(Preece, 2002)

The development of the interactive system described in this thesis is guided by user-centred design principles. A thorough identification of all user/stakeholders and understanding of their needs is essential to successful design as aphasia (and stroke in general) have far-reaching consequences not only for the affected individual, but also for the entire community that the affected individual is a member of.

The methods of enquiry employed to achieve this objective included readings in clinical practice and theory, observation of clinical speech therapy sessions, informal interviews with expert users, and evaluations by expert users. The determination of the primary user-patient's needs with his/her direct involvement was not possible during this phase of development due to ethical testing requirements and time constraints, and the ethnographic work this entails awaits.

The work of this project has been specifically directed to creating two interactive exercises to augment and accompany those used in standard speech therapy sessions – word finding and sentence construction. The screen layout, method and manner of interaction, are based on readings in both aphasiology and neuropsychology, and the setting of design requirements have been guided therefrom.

This section then describes the two aspects of design consideration, user needs and system interaction. The section concludes with a summary of design requirements.

2.2 Requirements based on user needs assessment

The degree to which the needs of users and stakeholders can be met depends on a complex set of interrelated factors including, among others, the patient's mental outlook, access to

adequate therapy and caregivers' time and patience. It is our belief that a well-designed system for computer-assisted language rehabilitation can positively affect these factors, and help to alleviate the current crisis due to underfunding for SLT services in Ireland. In Table 1 we propose a method for the qualitative assessment of benefit that such a system does (or does not) offer. The user/stakeholder is asked to assess the relative merit on a scale from 1 to 5 – 1 signifying no perceived benefit, 5 signifying maximum perceived benefit.

Individual user/stakeholder needs are described in the following sub-sections.

User/Stakeholder	Outlook	Access	Communication
Patient			
Therapist			
Caregiver			

Table 1: Perceived benefit assessment

2.2.1 Patient

The first obvious need for the primary user, the aphasic person, is restoration of language ability in order to communicate daily essential needs to caregivers. Impairment radically alters the course of many patients' lives. It is not possible for some patients to continue in a line of employment where verbal and written communication are essential requirements. Intellectual and creative pursuits that rely on language ability must be forsaken or curtailed.

Social intercourse within family and community is impeded. The consequences of such drastic curtailments to work, leisure, and involvement in community can lead to depression and despair.

Requirement: Facilitate the rehabilitation of the aphasic user's language ability and integration within family and community.

2.2.2 Therapist

The therapist's obvious first duty and need is to work with the patient towards restoration of language and reintegration of the patient into the family and community. As a professional expected to perform to standards defined by both an accrediting organization and employer, the therapist also has a need and right to working conditions that are conducive to these

needs. Unfortunately it would appear that the SLT profession both here in Ireland and in the UK is underfunded, and that as a consequence SLT professionals are overworked.

With specific regard to the dire lack of trained speech language therapists in Ireland, we quote from a speech delivered by TD Gerard Murphy on Mon 18 November 2004 to Dail Eireann during the debate on the Disability Bill, 2004:

“For the past three years the parents have protested outside the Midland Health Board about the lack of facilities for their children. Some of the children were getting one hour of speech therapy per year. When I quoted that fact the journalists got it wrong. They probably could not believe that the children were getting only one hour per year so they referred to it as one hour per week. However, many of the parents would be delighted if their children could get one hour per week.”

The National Rehabilitation Hospital in Ireland is funded for only 5 rehabilitation beds for people under 65, while some acute units elsewhere lack both speech and language and occupational therapy (Irish Medical News, 2001). SLP and SLTS in Ireland are, in short, underfunded and overworked.

Requirement: Assist the therapist in the practice of his/her profession.

2.2.3 Caregiver-stakeholder

The impact of stroke creates burden and strain for caregivers. Five studies cited by Rombough et al. in Rehabilitation Nursing indicate “a significant association between poor health of caregivers and increased caregiver burden or strain.” (Rombough, 2006). Support for the primary caregiver is critical to his/her ability to assist in the process of rehabilitation and reintegration into family and community.

Requirement: Reduce the caregiver’s burden of strain.

2.3 Requirements based on specific impairments

In this section we describe impairments to cognitive and motor functions that can accompany aphasia. Accommodation of these impairments is essential to facilitation of cognitive stimulation. The treatment approach known as cognitive stimulation or stimulation-facilitation that has been formulated and described by Schuell, Darely, Brookshire et al. and underpins the design approach of this system. Advocates of this method argue in favour of stimulation of cognitive processes over replication of tests and targeting specific stimuli and responses. Further discussion of this and related topics is included in Section 7 below.

2.3.1 Visual impairment

A loss to either the left or right half of vision (*homonymous hemianopsia*) can occur when a lesion affects the area where the optic nerves cross in the brain (optic chiasm). Since stroke resulting in aphasia results from a lesion in the left hemisphere, patients thus affected who are also afflicted with a hemianopsia will experience a loss of vision in the right half of the visual field of both eyes.

Requirement: Consider right cut impairment.

2.3.2 Comprehension impairment

Most aphasic persons have some degree of impairment to short-term memory. This design consideration will apply to visual and especially auditory information. Auditory information is transient, while visual information is persistent. Auditory information that is used for cueing purposes should be available on demand.

Requirement: Keep sentences short and simple.

2.3.3 Motor impairment

Paralysis (*hemiplegia*) on the side of the body opposite the brain's language-processing areas can result from stroke. Input devices that require a high degree of manual dexterity or coordination (e.g. standard qwerty keyboard or graphics tablet) will entail difficulty for the user and impede cognitive stimulation.

Requirement: Strive for minimal physical effort.

2.4 Requirements based on readings in aphasiology and neurophysiology

PRAXIS is designed both for use in therapist-guided sessions and for use by the aphasic patient without assistance. In sessions involving patient and therapist, difficulties of perception and comprehension experienced by the patient can be alleviated by the intermediation and interpretation of the therapist. If the system is to function effectively in solo sessions it must successfully focus the patient's attention and awareness on activities in a clear and easily comprehensible manner. The following sections discuss the concept of attention as described by cognitive neuropsychologists, phenomena of attention as revealed in neurophysiological experiments, and design requirements are set forth.

2.4.1 Attention

"It is the taking possession by the mind, in clear and vivid form, of one out of what seem several simultaneously possible objects or trains of thought. Focalization, concentration, of consciousness are of its essence. It implies withdrawal from some things in order to deal effectively with others,"

(William James, 1890)

Davis, in his standard reference on aphasiology, presents the following table of the levels and types of attention (Davis, 2000).

arousal	state of consciousness; primitive wakefulness	gross motor response to sensory stimulation
awareness	assumes arousal; from stupor to clear perception of surroundings	answer questions
selective attention	focus; resistance to distraction; managing limited resources by selection	two stimuli or tasks; response to one (e.g., dichotic listening)
sustained attention	vigilance or concentration; maintaining focus on one stimulus for a period of time	a series of stimuli and response to one
divided attention	allocating limited resources to multiple processes or tasks	two stimuli or tasks; response to both (dual task paradigms)

Table 2: Levels and types of attention

Previous studies of the effects of divided attention during tasks requiring concentration on tonal and verbal information indicated a reduction in the aphasic person's concentration when presented with a simultaneous task (Erickson et al. 1996 cited in Davis 2000, LaPointe and Erickson 1991, respectively). Optimal cognitive stimulation is realized during selective and sustained levels of attention, and impairments to attention mechanisms are adversely affected by multiple stimuli.

Requirement: Reduce stimuli to the lowest possible number.

2.4.2 Visual Cueing

2.4.2.1 Enhanced detection

Research into the behavioural consequences of attention has revealed that accuracy of detection and faster reaction times are improved by visual cueing. In an experiment that studied the effects of directing visual attention to different locations, it was discovered that visual cueing improved target detection although the point of focus of the subject remained fixed (Posner et al. 1980 cited in Bear, 2007). Refer to Figure 4 for a detailed explanation of this experiment.

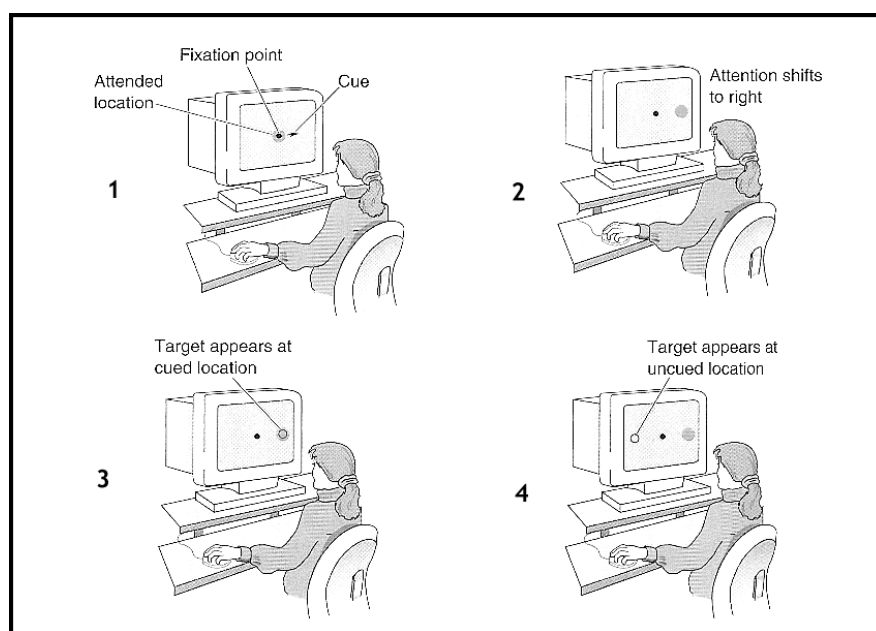

Figure 4: Enhanced detection by cueing

A point of central focus is established for the observer (1). The observer is asked to determine whether a flashed target stimulus occurs to the right or left of the fixation point. Prior to the appearance of the target, a visual cue is presented either as an arrow pointing to the left or right of the fixation point, or as a plus sign (2). If the cue presented is an arrow, the target is presented on average four times in the location indicated by the arrow (valid cue), and once on the side opposite the arrow (invalid cue). If the cue presented is a plus sign, the target is presented equally on either side. The results of this test revealed that the highest rate of detection occurred when an arrow pointed to the correct location of the target (refer to bar graph).

Whether the inclusion of visual cues, or primes, will aid the process of rehabilitation, or only

facilitate the selection of the correct answer and therefore offer no improvement in the generalization of learning has not been determined. We hypothesise that visual cues to correct answers will result in a decrease in motivational stimulus. However, we sought evidence of an increase in attention that we believe this experiment provides, and have incorporated primes not as cues to correct answers, but as an attention-focusing device. A further description is included in the Section

Requirement: Provide visual cues.

2.4.2.2 Phonological and semantic cueing

Semantic and phonological cueing techniques are routinely used in clinical SLT practice. Studies of phonemic cueing and semantic facilitation of word finding indicate improvement of patient's word retrieval ability. While evidence of long-term effects of trained items exists, evidence of spreading generalization, that is generalization that proceeds from trained items, is inconclusive (Howard, 1994). It would seem logical to assume that computer-assisted methods that employ similar techniques would produce similar results, and evidence of benefits in both clinician-guided and patient self-guided work with computerised cue naming exist (Fink, 2002).

As a general observation, research methods, study group sizes, the inclusion or omission of control groups, testing standards, and protocols, vary considerably, and evidence of therapeutic benefit is inconclusive. Robey and Schultz propose a model for conducting clinical outcomes, citing existing formal processes codified and defined by the World Health Organization (WHO), US Office of Technology Assessment (OTA) and Food and Drug Administration (FDA). Referring to research within the field of aphasiology, the authors state, "The assertion that treatment is effective based on a body of clinical-outcome research does not invalidate the criticism that individual studies are enormously heterogenous in terms of content and quality." (Robey and Schultz, 1998)

Notwithstanding this criticism, design consideration proceeds on the evidence of positive benefits of phonological and semantic cueing.

Requirement: Provide phonological and semantic cues.

2.4.3 Requirements based on clinical practice

A cursory acquaintance of clinical practice was gained with assistance from the University's

department of speech and language therapy. The department provided access to live and videotaped therapy sessions, SLT workbooks, and conversations and informal interviews with the department head and clinic supervisor.

Observation of live clinic sessions took place in the clinic's monitoring room. This room consists of LCD displays that monitor four therapy session rooms. The clinic supervisor provided verbal descriptions of patient syndromes, therapist and patient interaction, group interaction that took place in one of the sessions, and clinical methods and desired outcomes during the observation. The department also provided several hours of videotaped sessions and SLT workbooks. The researcher gained further understanding from conversations and informal interviews with the department head.

Methods used as observed in clinical sessions lend support to the requirements developed in the previous section, and a summary of these and system design requirements is provided in

Requirement: The system shall augment methods used in clinical practice.

3 System Design

As the system is designed to augment clinical practice, the choice of hardware and design of the program interactions were necessarily contingent on those requirements established in the previous section. Those requirements are reiterated within each sub-section where applicable, and additional requirements germane to physical interaction are developed and discussed below.

3.1 Hardware

3.1.1 Computer

Requirement: Cross-platform operability.

As **platform independence** was desired, Adobe Flash was used to develop user interactions. Flash swf files run on either Windows (98/ME/2000/XP/Vista) or Mac OS X (Intel, Power PC) platforms. In addition, as the swf file can be accessed over the Internet via HTTP protocol (with Flash Player embedded in the client browser), interaction under Linux x86 and Sun Solaris (Intel x86 and Sparc) operating systems is also possible. The use of a RFID reader from a non-local domain has not been implemented in this prototype.

The computers used in the development of the prototype included an Apple MacMini

(PowerPC), and a Shuttle PC. The bulk of the software interaction work was accomplished on the MacMini primarily for the convenience of portability that the computer's small size offered. The Shuttle PC was used for the operation of the prototype during demonstrations, as it runs all system components and provides serial connection to the RFID reader, IP socket hosting, read/write operations from/to RFID tags.

PRAXIS can be operated on a single computer (PC or Mac) that has a either RS232 serial port or, USB port with external USB to serial converter, serial port driver for RFID reader, and an operating system that supports TCP/IP socket connections. As of this writing, only a PC serial driver is available for the RFID reader (Texas Instruments Tag-It 6000).

3.1.2 Keyboard

“Our intention was to rejoin the richness of the physical world in HCI.”

(Ishii and Ullmer, 1997)

It is our contention that the computer keyboard presents a significant obstacle to computer-assisted language rehabilitation. There are additional demands on motor activity when compared with handwriting, and physical obstacles for stroke patients with motor difficulties. The keyboard also imposes additional demands on cognitive processes that constitute an interruption in the natural flow from graphemic imaging to cursive alphabetic writing. Keyboard entry requires either the mapping of the internal image of graphemes to the internal image of a keyboard layout or the interruption of the orthographic feedback loop (that is, the flow of written information from hand to eye) in order to determine the location of letters on the keyboard. Our search of literature on the subject has, surprisingly, only uncovered two relevant articles. These articles deal with a) the feasibility of and b) the advantages of gestural vs. keyboard input (Keates and Robinson, 1999 and Wolf, 1992, respectively). No literature has been discovered that considers either the obstacles imposed by QWERTY keyboards or viable alternatives. (This is not to suggest that such literature does not exist, but that it could not be located in the time available to the project.) As it was not possible in the time available to investigate or devise a possible alternative, we decided to eliminate keyboard input as a perceived obstacle, and instead substituted pen/touch-screen display and RFID tag/reader interaction (“tangible bits”).

If we consider the exchange of information between user and system in a layer model of

human-computer interaction where physical exchange of information exists as a bidirectional flow between system and user, we can envision the rate of flow of the exchange of information from user to system increasing when the additional cognitive demands imposed by keyboard and mouse are removed (Ziegler, 1988).

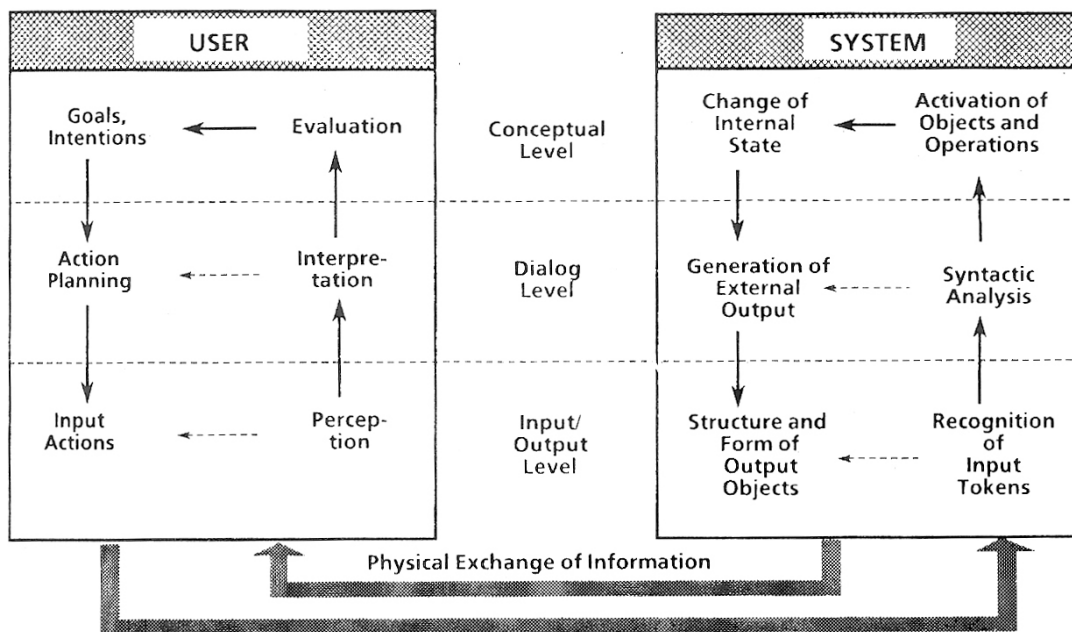

Figure 5: Layer model of abstraction in human-computer interaction

3.1.3 Display

3.1.3.1 Type

As a result of stroke, the aphasic patient suffers from cognitive disconnection or dissociation. This difficulty in language processing is often a source of frustration and despair for the patient. Additional obstacles presented by computer-based activities would be counter-productive both to the patient's desire to restore language function and the designer's desire to create a useful tool. The indirect manipulation of screen objects by keyboard and mouse create obstacles that constitute another type of disconnection for the aphasic user. Ziegler and Fähnreich refer to these impediments as the gulfs of execution and evaluation (Ziegler and Fähnreich, p.124 in Helander, ed. 1988)

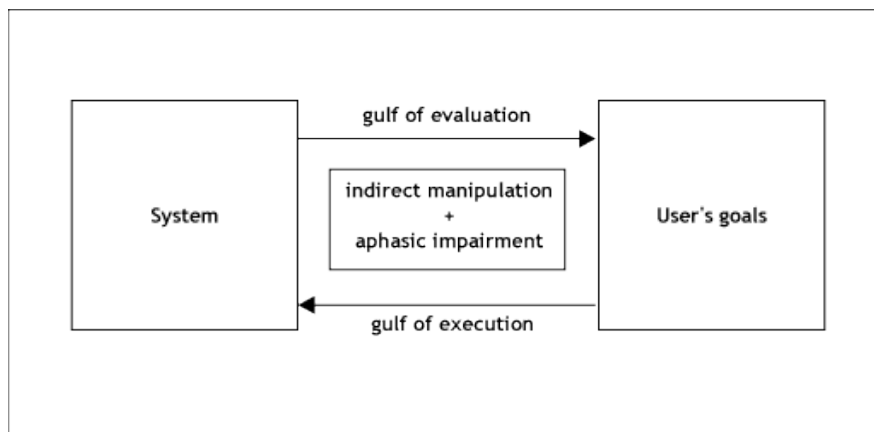

Figure 6: Gulfs of execution and evaluation

If we consider their conceptual model above, we can consider the language impairment of aphasia as an additional layer of execution and evaluation gulfs. The obvious solution to the problem of indirect manipulation is substitution with direct manipulation, hence our decision to use an interactive touchscreen display.

Pointing accuracy of touchscreens was considered, primarily where significant error rates could lead to user frustration, and Shneiderman's comparison of high-precision touchscreens and mouse revealed no difference in performance for targets ranging from 32 to 4 pixels wide (Sears and Shneiderman, 1989). The current specifications for commercially available touchscreens would appear to support higher rates of accuracy and precision. Published specifications of one 17" surface-capacitive touchscreen monitor claim 1.5% accuracy, with a touchpoint density of 4096 x 4096. Touchpoint density therefore exceeds pixel density of typical screen resolutions.

Requirement: The display shall afford direct manipulation.

3.1.3.2 Screen size

Hypothesis: Large screen sizes will improve attention and task performance.

As the widespread availability of large screens for computer displays and home entertainment systems is quite recent (<10 years), there are relatively few comparative studies of the possible benefits of large vs. small screens. However, evidence presented in one such study (Tan, 2004) did not bear out the hypothesis that large displays would improve task performance. While Tan's tests provide evidence of improved performance in spatial tasks, no improvement in reading comprehension was found – a primary activity of our system at its

present stage of development. De Bruijn's (De Bruijn et al., 1992) results, which compared 12" and 15" screens, revealed a decrease in learning time, but no improvement in learning performance. The now not-uncommon use of substantially larger screen sizes of 21" and larger would suggest a revised study. No requirement for screen size was established from this.

Requirement: The display shall accommodate simultaneous interaction by two users.

The second consideration in arriving at an appropriate screen size is the requirement for simultaneous display interaction of therapist and patient. Interaction scenarios were envisaged where a) the therapist would trigger auditory cues for the patient and b) where the therapist would provide guided instruction to the patient. We measured the span of an average-sized hand (male) in a relaxed position with extended index finger at ~16 cm. which indicates a ~32 cm minimum screen width (16 x 2). Taking 5:4 as standard screen aspect ratio of commercially available monitors, this indicates a **minimum screen size of ~16"** diagonal ($\text{SQRT}(32\text{cm}^2 + 25.6\text{cm}^2) = 40.98\text{cm} = 16.13"$).



Figure 7: Two users interacting with touch screen (17").

3.1.3.3 Screen height and orientation

"If the environmental demands correspond to capabilities developed through evolution, mastery has few negative consequences."

(Fostervold, 2001)

Hypothesis: Lower display height and angle and shorter distance from user to display will result in reduced physical effort compared to typical display positions.

The decision to use a touchscreen display led us to an examination of ergonomic factors. Given diminution of visual ability as an age-related factor, and possible post-stroke motor impairment experienced by the aphasic, we felt that user fatigue was a necessary consideration, particularly in the user's home environment where the computer can be used for longer periods than in the clinical session. Musculoskeletal strain might result from uncomfortable seating positions and from the increased effort required to keep the arm extended while touching the screen. Visual strain might result from suboptimal screen height, angle of tilt, and distance from the user.

The hypothesis stated above was based on the simple observation that human beings have been gazing down at horizontal work surfaces for hundreds if not thousands of years, and that such an arrangement has been a natural development. We reviewed ergonomic studies on display position, preferred viewing angle, and muscle activity and fatigue. While data bore out our assumption that a gaze directed below the horizontal line (*See Figure 8*) is a preferred line-of-sight, there was no general agreement on optimal display placement or viewing angle. What seems clear is that individual preferences dictate flexibility in location of, and distance from the display. We found no studies that compared effects of display interaction with conventional desktop work of reading and writing on the desktop. It may be the case that as the depth of CRTs (which were the common display type during the times of the studies) did not permit easy rotation of screens into angles approaching the horizontal, researchers investigated angles where the back of the CRT did not rotate below the work surface. The gradual replacement of the LCD display as standard in work and home should prompt a rethinking about optimal viewing angles and placement.

While studies vary with regard to exact angles, there is agreement as previously mentioned that the natural resting position of the eyes when the head is upright is downward, and that the point of vergence (relaxed eye position) decreases from an average of about 1m at a downward angle of approximately -24° to .5m when the angle is approximately -30° . The implication here for display position is that decreasing the display height as distance decreases will require less physical exertion, as effort is required to move the eyes from the point of vergence (Heuer et al., 1991 and Fostervold, 2001).

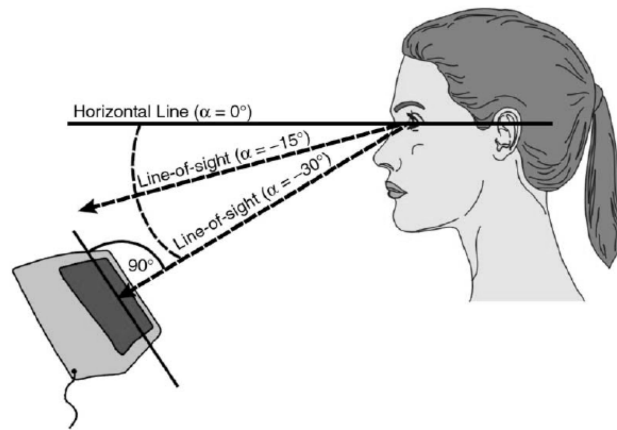

Figure 8: Horizontal line and line-of-sight.

We took advantage of the opportunity that this phenomenon provides (to reduce musculoskeletal and visual strain) by bringing the display closer to the user. This was made possible by removing the keyboard. As the distance from display to user decreases, the optimal viewing angle increases (from the horizontal). Therefore we wanted to position the display to minimize musculoskeletal and visual effort: shorter reach, lower arm position, and larger display image in the field of view. In view of studies that reveal individual preferences (e.g., Jaschinski et al., 1998) and without as yet the benefit of our own empirical observation, we cannot specify an exact screen angle, but accept that 30° seems to be a reasonable starting point.

Requirement: The display shall be capable of rotation to an angle at least -30° below the horizontal line.

Requirement: The display shall be in a position requiring minimal physical effort.

3.1.3.4 Wacom Cintiq

Ideally we would prefer a touch screen display rather than an interactive pen display, as pen interaction still constitutes indirect manipulation (although significantly less than mouse/cursor interaction.) The display that was available for prototype development in this phase was the Wacom Cintiq 21UX interactive pen display. The display satisfied all but one of the established requirements:

1. The display allows direct manipulation of virtual objects (partial).
2. Screen size is 21.3” and can accommodate simultaneous interaction of two users.

3. The display can be tilted from 10° to 65° from the horizontal.
4. The interactive pen requires basic manual dexterity.



Figure 9: Wacom Cintiq 21UX

The Cintiq display is an integrated monitor and tablet. The 21.3” LCD screen is a TFT active matrix LCD monitor with a maximum resolution of 1600 x 1200 pixels. Beneath the TFT screen is an electromagnetic grid of horizontal and vertical wires with a reading resolution of 200 lpmm (lines per millimetre). This resolution of 0.005 mm is accurate to within ± 0.5 mm.

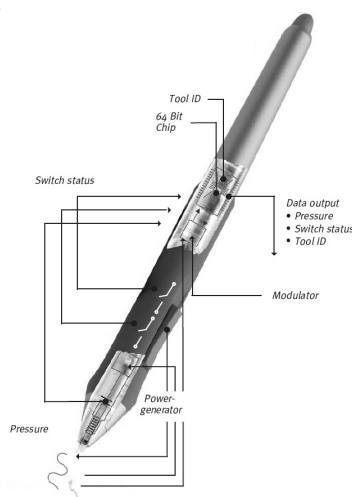

The Cintiq pen operates by the principle of electromagnetic induction. A coil-and-capacitor circuit in the pen resonates at the operating frequency of the display’s electromagnetic grid. The energy required to power the circuitry is small enough that the pen requires no power supply. Signal information from the grid is demodulated, and passed to a

processor chip in the pen. Pen pressure, ID, and switch status, are combined with positional information and passed back to the grid circuitry. Pen events (drag, switch down, and pressure levels) are passed to the host application.

3.1.4 RFID Hardware

3.1.4.1 Introductory remarks

Radio frequency identification (RFID) technology was chosen as a means to provide direct and tangible interaction with the virtual environment. The wireless detection of RFID tags allows a physical separation of tag/tokens from the computer interface. This separation

renders tags as a class of objects with meaning and tangible presence independent of the virtual environment. In fact, in the interaction we designed to treat agrammatism, phrase tags can be used with or without the computer. These cards can be held, felt, and moved freely in space. We feel this will provide a greater stimulus to the language-impaired user. Other tag technologies exist, but wireless technology affords greater freedom between tag and reading device. For example, barcode tags require direct line-of-sight and magnetic cards require alignment of the magnetic strip.

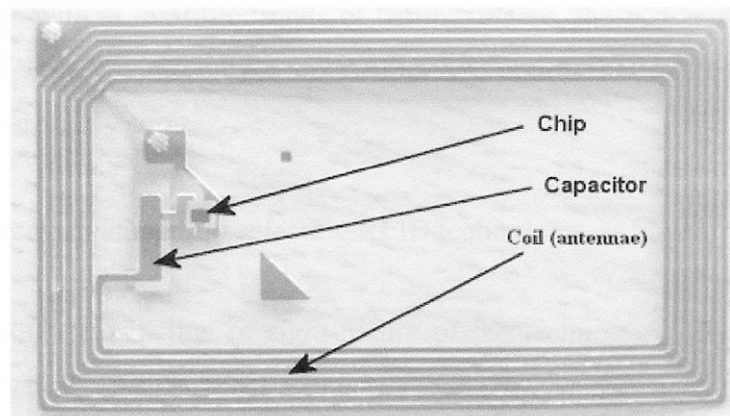

Figure 10: Texas Instruments RFID tag

As implemented in the prototype, tags function as tokens, not literal representations of orthographic information. In other words, while the surface of the tag covering is printed with words, the information embedded in the tag is a unique number that is used by the program for array lookups. Ideally, we want the administrator-therapist to be able to program tags through the direct entry of text. This will enable the administrator-therapist to create customised tags with words and sentences in order to better serve individual patients' needs. While it may be possible to provide this feature by directly storing alphabetic data, or encoding it with an algorithm (and to decode when reading) storage capacity of RFID tags may prove to be a limiting factor. (The tags we used in the prototype (Texas Instrument Tag-It™ Inlays) have a storage capacity of 256 bits.) And further development of the system may require evaluation of other technologies.

3.1.4.2 Texas Instruments Tag-It 6000 RFID

While the widespread use of RFID technology is relatively recent, investigations of RFID

technology date back at least as early as 1948 when the paper “Communication by Means of Reflected Power” by Stockman was published in the 1948 Proceedings of the Institute of Radio Engineers. Widespread use of RFID technology did not take place until the 1990s with the incorporation of RFID devices for automatic toll collection. Research and development continued during the 1990s, and the arrival of the single integrated circuit tag represented a significant step forward in RFID capability (Landt, 2001). There are three types of tags in use; passive, active, and semi-passive. We will confine our description to the actual RFID read/write system used in the prototype (passive tag), the Texas Instruments Tag-It™ 6000.

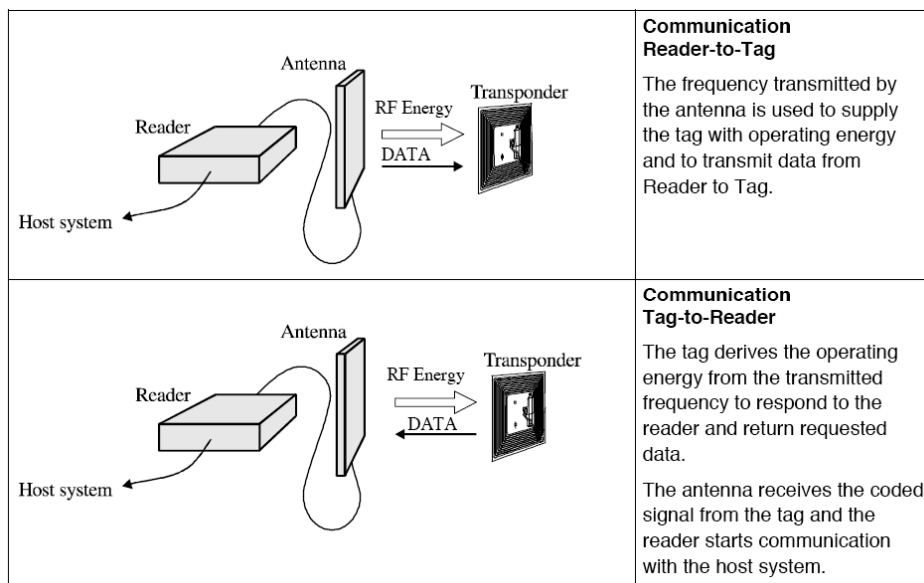

Figure 11: RFID Tag and Reader Operation

The 6000 Series read/write hardware pictured below consists of an antenna, reader and connecting cable, and RS-232 cable to connect the reader to control device (computer). When a tag is present within the operating range of the antenna (typically 13 cm), a voltage will be induced in the tag. This provides sufficient energy to power the tag’s circuitry, thus enabling initiation of read/write operations by the host computer. Passive tags do not initiate read/write activity.

A circuit schematic of the RFID tag or transponder (transponder connotes the tag’s ability to send and receive signals) is inset in the lower right-hand corner: Capacitor (C) and Antenna (L) form a ‘tank’ circuit that by a resonates at a frequency given by the formula:

$$f = \frac{1}{2\pi\sqrt{LC}}$$

Figure 12: Formula for resonant frequency of a tank circuit.

The operating frequency of the reader is 13.56 MHz, and data written to and received from tags is superimposed on the carrier frequency by Manchester encoding. In the 6000 reader, digital data is encoded by the modulation of the carrier frequency by 423.75 KHz (high level) and 484.29 KHz (low level) signals. Circuitry that detects, or “discriminates” decodes the superimposed digital signals.

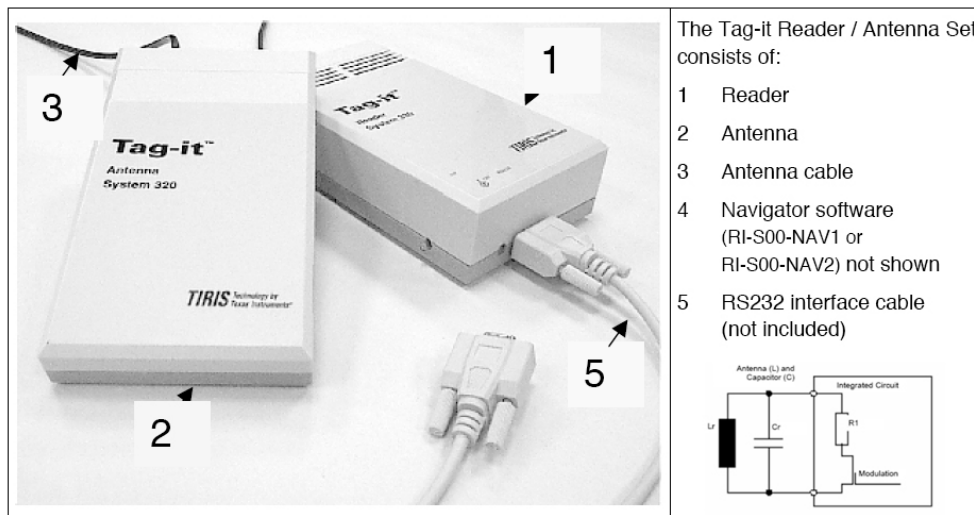

Figure 13: Texas Instruments Tag-It Reader 6000

3.1.4.3 Handling RFID Connections

A stand-alone serial driver serves as a software link between the RFID reader and local or remote computer. The driver performs two functions; 1) it establishes i/o operations with the RFID reader over an RS-232 connection (or alternatively via USB with a serial to USB converter) and 2) transfers RFID data to the requesting client (in this case Flash) either locally (local client in Figure 14) or over a TCP/IP connection (remote client in Figure 14). Once the socket connection is opened, it is maintained by the host computer as a persistent connection. A diagram of local and remote connections is shown in Figure 14, with a sequential listing of events for both.

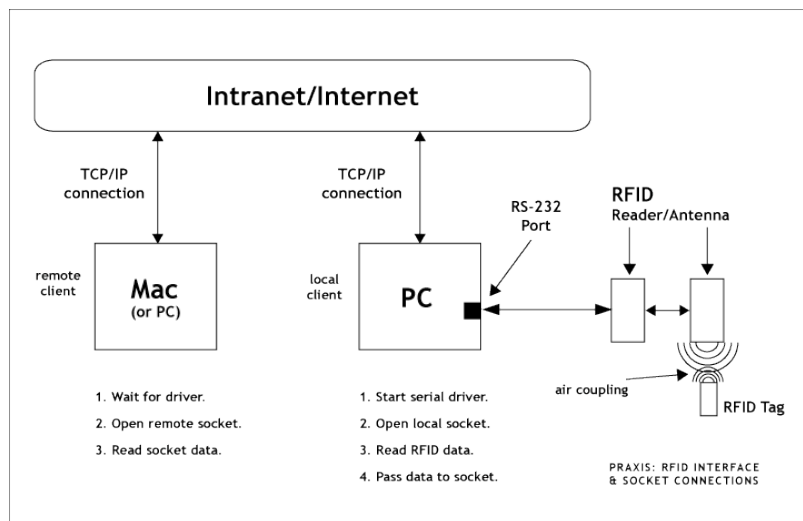

Figure 14: Connecting RFID reader to PC and Mac

3.2 Software

3.2.1 Overview.

The core elements of this project consist of interactions that augment standard methods of speech language therapy for adult aphasics. These interactions are designed to be used in clinical therapy sessions between patient and therapist and in the patient's home or other location where a computer is available. In the clinical setting, interactions can serve as goal-oriented problem-solving activities, or as a visual stimulus to conversation and other language rehabilitative activity. Activities were not designed to be test-based. If the response to a question is incorrect, the user can reset the interaction to the initial state. We believe that the patient and deliberate process of learning in a relaxed environment is one of the great assets of human-computer interaction. Computer learning rewards that greatest of motivations, natural curiosity. Interaction is modeless¹, and users can end an activity and return to the main menu at any point.

Requirement: Create a modeless interface.

A key design objective is to afford a sensory-rich experience (sight, sound, touch) to stimulate and engage the user. All interactions contain graphic, orthographic, and auditory

¹ See "Human Interface Design Principles" for a description of modelessness and other key HCI principles. available: http://developer.apple.com/documentation/UserExperience/Conceptual/OSXHIGuidelines/XHIGHIDesign/chapter_5_section_2.html#//apple_ref/doc/uid/TP30000353-TPXREF110

information. Graphic and orthographic elements are presented in a persistent state, and interaction involves the sense of touch. Auditory information affords on-demand sound cueing in a sequence of increasing complexity (i.e., phoneme, syllable, word or phrase, sentence). Photographic images are used with a view to engaging and motivating the user to proceed past the specific goal of the exercise to verbal communication. Line drawings are used for more straightforward goal-oriented activity. While the prototype offers only a limited set of examples, collaborative work will continue with speech language therapists to further define and develop the project.

Technical requirements of integrating touchscreen display and RFID reader arose from the decision to substitute keyboard and mouse interaction with input devices that facilitated direct manipulation. The incorporation of touchscreen interaction was straightforward, as touchscreen manufacturers provide drivers for most major operating systems. Interaction via a RFID reader created additional requirements however, as no standard methods (or driver code) for the envisaged interaction currently exist. Fortunately, RFID driver code that had been written during previous work within the Interaction Design Centre simplified the integration of the reader,² leaving only the coding necessary to read and integrate tag data into the interaction.

3.2.2 Establishing Software Requirements

Adobe Flash® Professional 8 satisfied the requirements shown in Table 3: Software program requirements. The table lists the device, device requirements, and a partial set of Flash ActionScript classes, global functions, handlers, or methods that satisfied those requirements. Routine handlers and functions (e.g. buttons) were not included in the table. The reader is referred to the ActionScript code section of the appendix.

² See <http://www.ul.ie/main/news/index.shtml> for a description of the “*Recipe Pyramid*”. In this interactive installation, RFID tags printed with names and images of food ingredients were dropped into a plexiglass “pyramid” by food shoppers. Recipes with matching ingredients were subsequently printed for the customer.

Device	Requirement	ActionScript Class
RFID reader	Communicate with reader for read operations	XMLSocket (Class) XMLSocket.connect (method) XMLSocket.onData (handler)
Computer	Sound processing capability	Sound - (Class) Sound.start() - (method) Sound.stop() - (method)
	Dynamic text rendering	MovieClip.createTextField() - (method)
	Drag and drop interaction	startDrag() - (Global function) stopDrag() - (Global function) hitTest() - (method)

Table 3: Software program requirements

Communication with the RFID reader was achieved with the use of a serial driver written in C++. The driver exists as a standalone file, and must first be opened before attempting a socket connection. (As previously mentioned, this driver was developed in earlier IDC work). At present only a PC version of the driver is available. It is anticipated that this driver will be adapted to run on both PC and Mac platforms as an integrated Flash component during the next phase of development as C-level extensibility is incorporated into Flash with Flash and Javascript APIs. At present a persistent socket connection is maintained once opened. Should the program be hosted by a server for multiple http sessions at a future date, efficient resource usage would indicate including methods for closing timed-out connections.

3.2.3 RFID Interaction.

This interaction was designed to treat agrammatism, a disturbance to sentence planning and production that is characterized by omission of grammatical words and reduced utterance length. A patient manifesting symptoms of agrammatism might for example verbalize the grammatically complete sentence “I went to the bank to get money”, as “Bank...money.” The term “telegraphese” is often used to describe this syndrome.

The underlying concept of this exercise is based on the theory that agrammatism represents a difficulty in forming structural representations (Luria in Davis, 2000). In order to assist the rehabilitation of that process, we have deconstructed sentences into phrases which represent the principal elements of agent, action and object. We wrote token data for these elements on RFID tags with the Tag-It reader, and printed the text on the enclosing paper (refer to Figure 15). The object of the exercise is to present tags sequentially in the correct sentence order.

When a tag is presented to the RFID reader, the corresponding phrase printed on the tag appears on the display.

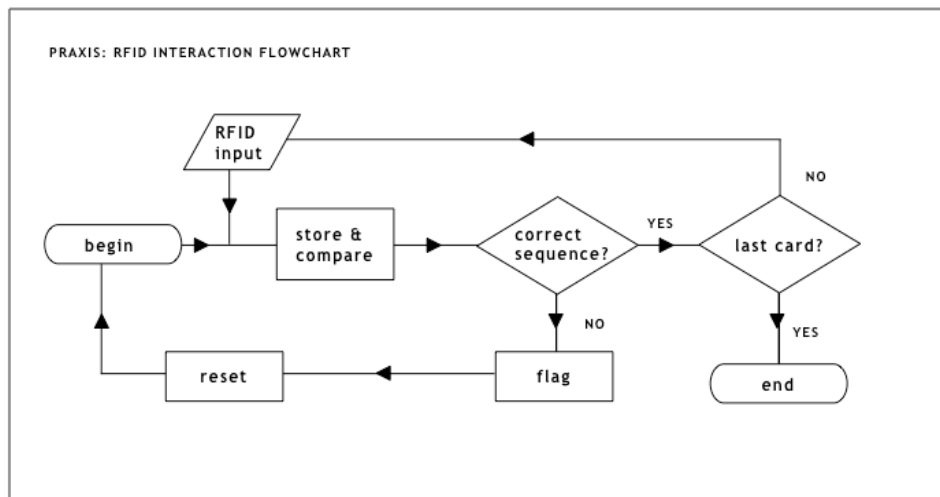

Figure 15: RFID Interaction Flowchart

How it's coded: The RFID tags are encoded with unique incrementing numeric values. When a tag is read, the numeric value is entered into an array, and compared to the element number of an array containing the sentence. A dynamic text field object containing the sentence array element is then created and displayed. Visual feedback indicates to the user whether the sequence of presentation is correct or incorrect: If the phrase ordering is incorrect, the user is alerted by the appearance of the phrase in red and the appearance of a "redo" button.

In the example depicted below, the sentence "The girl is running home with her dogs," is broken into the grammatical elements "The girl", "is running", "home", "with her dogs" (noun/agent, verb/action, object, prepositional phrase/noun phrase respectively).

3.2.4 Touchscreen interactions.

3.2.4.1 Lessons learned during the design process.

I will digress briefly in this section to share with the reader insights gained and lessons learned while designing screen layout for a touchscreen interaction. During this process, I discovered a number of erroneous assumptions and omissions concerning target visibility, object persistence, quantity, and placement which reveal both my own biases, and certain aspects relevant to interface design in general, and specifically touchscreen interaction.

From reading and observation, I came to several conclusions that precipitated changes in

layout and design of screen elements used in touch screen interaction. In the first design iteration of the graphic object to word matching exercise, I centred the graphic object on the screen, and surrounded it with eight categorically related words. These eight words would persist during consecutive quizzes while the graphic object changed. This would, I thought, address the category-specific impairment investigated and described by Caramazza (Davis 2000, p.85) and Warrington and Shallice (Caplan 1987, p.193), where dissociation exists mainly with respect to animate and inanimate objects. Cursory reading on the subject of short-term memory (Cowan, 2000 and Bear, 2007) however, led me to a different conclusion. While there is no agreement on the number of items or “chunks” that can be retained in short-term memory, 7 is generally accepted as a maximum. Given the reduced sensory processing ability of aphasics and the possibility of sensory overload, I discarded this approach in favour of a simpler matching exercise. Exploring workbooks and conversing with an aphasia expert suggested work in this direction. The first and second iterations are pictured below. Training with lists of related words (1) has been changed to phonologically related words (2).

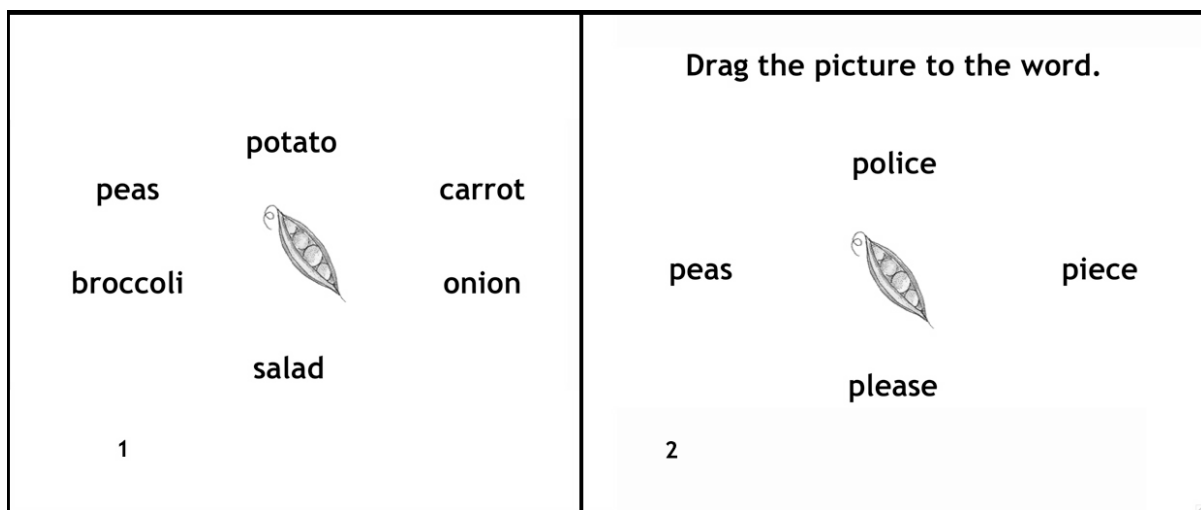

Figure 16: 1st and 2nd iterations of picture-word matching exercise

Next I observed two more problems; targets were not clearly defined, and visual persistence of targets was compromised by placement. I attributed these oversights to a bias formed by the use of a mouse and cursor as my primary means of screen manipulation. While the circular arrangement of words about the graphic object offers an advantage in speed of

access,³ items at the bottom of the screen are obscured by the user's hand. In the example shown, the word please (number 2 in Figure 16) is obscured as seen in the left-hand image of Figure. In the right-hand image (the fourth iteration) target boundaries are clearly defined, targets have visual persistence, and economy of motion is realized with the equidistance of object distribution along an elliptical path. Additionally, the graphic object has been rotated to match the rectangular border size of the words. The design is incomplete however: The requirements for auditory feedback and visual cueing of event detection have not yet been implemented (see evaluation 2 on page for further discussion).

One other question that arose concerns the use of colour. While the printed images in this text are greyscale, screen images contain colour. While creating a grayscale screen layout for rhyming pair matching (see description and screenshot below), I realized that the perception of colour involves different areas of the brain than language processing. If I act on the hypothesis that a reduction of visual stimuli will improve attention and retention, I should remove all colour. Or would the absence of colour diminish the user experience and engagement? Further study is required.

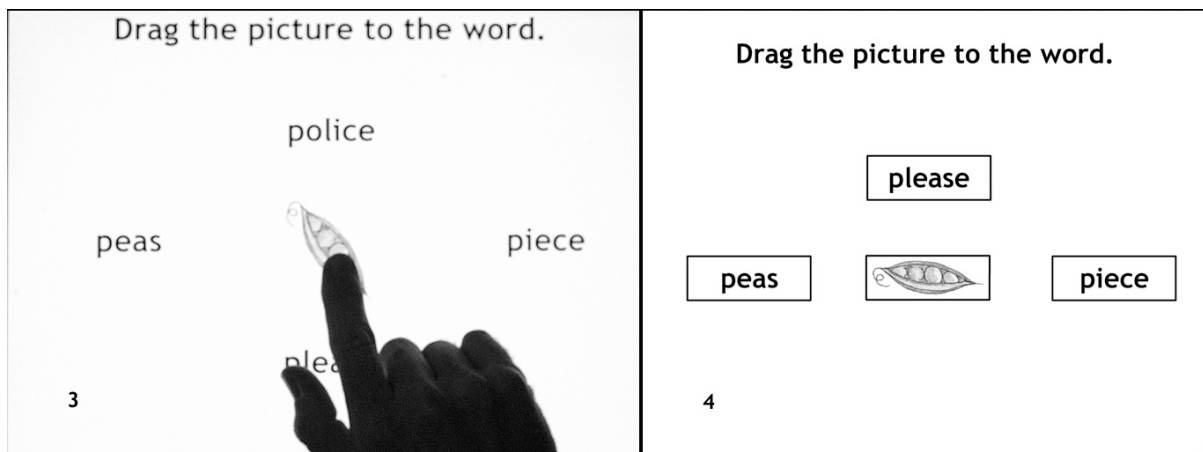

Figure 17: 3rd and 4th iterations of picture-word matching exercise

3.2.4.2 Screen design.

A library of learning interactions that are included in Flash Professional simplified development of interactions for word finding activities. Interactions were based on existing exercises as described in aphasia rehabilitation resource materials⁴. Graphic and word objects

³ Interface and interaction designer Bruce Tognazzini discusses the advantages of circular menus and other interesting considerations in interface design in “A Quiz Designed to Give you Fitts” at <http://www.asktog.com/columns/022DesignedToGiveFitts.html>.

⁴ SLT workbook sources are identified with the symbol ‡ in the bibliography.

are used as the primary triggering elements. Auditory cues with incrementally increasing clues are provided as user-triggered options. In other words, the user views pictures and words, and buttons that trigger auditory clues of phonemes, syllables, words, phrases and sentences are placed beside them.

Graphic design work was initially begun in Adobe Photoshop and Adobe Illustrator. However, as the current robust vector, bitmap, and text tools available Flash proved more than adequate for the task, most of the design and coding work was accomplished within a single program (killer app?). The reader should note that as of the date of this writing, screenshots pictured below in the descriptions of interactions are only mockups and not final designs. Explanatory text has been overlaid on the images to draw the reader's attention to functional system requirements.

3.2.4.3 Description of interactions for word finding with interactive display.

Picture to Word Matching. In this interaction, the user is presented with a graphic image, and several words – the name of the object, and distractors. The exercise is designed to improve naming ability. The task is to drag the graphic object to the correct word. When the dragged object enters the hit area of the word, the object snaps to the word. The user then checks whether the answer is correct or incorrect. If incorrect, the user is prompted to try again.

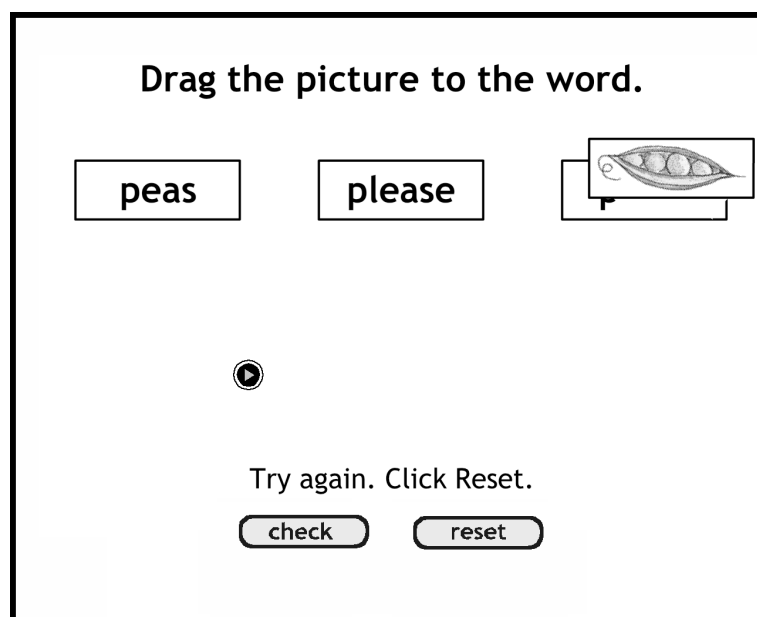

Figure 18: Word-picture match error

Sentence Completion. This fill-in-the-blank exercise is designed to improve verb and noun recognition. A picture is accompanied by a descriptive sentence. One word is missing. The user is given two choices which may be either phonologically or semantically-related.

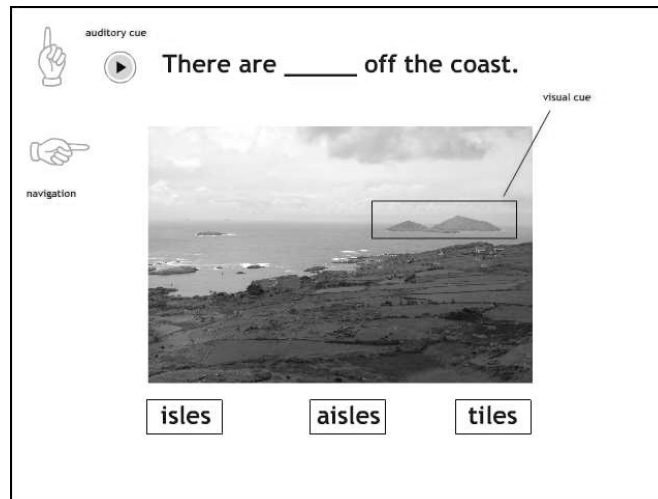

Figure 19: Fill-in Interaction

Element Identification. This exercise requires the user to identify elements of a scene or composite structure – in the example depicted, the user is asked to identify parts of the body. The exercise is designed to train semantically related categories of words.

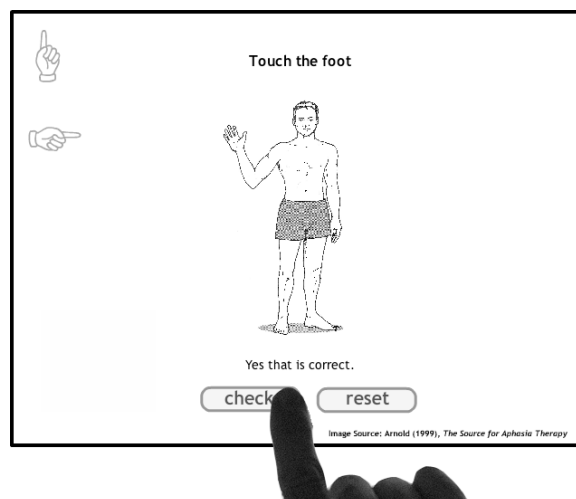

Figure 20: Element identification interaction

Picture Pair Rhyming. Three graphic objects are presented. The user is asked to touch the non-rhyming matching rhyme. Buttons that provide initial phonemic cues are placed beside each image.

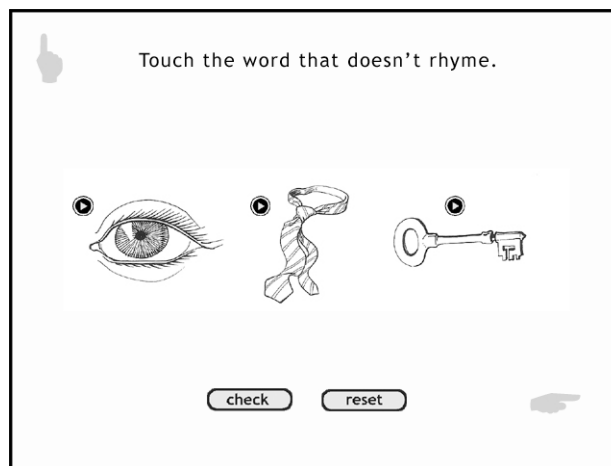

Figure 21: Rhyming pair matching

4 Summary of system requirements

With the exception of “right cut impairment”, all established requirements - user, hardware and software – were taken into account in the design process. Accommodating right cut impairment (by leaving 1/3 to 1/2 of the right-hand side of the screen blank) was deemed unnecessary by the aphasia expert. She maintained that aphasic patients are capable of compensating for this impairment (See Section 2.3.1 Visual impairment, p. 9 for a description).

4.1 User requirements.

- Facilitate the rehabilitation of the aphasic user’s language ability and integration within family and community.
- Assist the therapist in the practice of his/her profession.
- Reduce the caregiver’s burden of strain.
- Consider right cut impairment.

4.2 Hardware requirements.

- Cross-platform operability.
- The display shall afford direct manipulation.
- The display shall be capable of rotation to an angle at least -30° below the horizontal line.

- The display shall be in a position requiring minimal physical effort.
- The display shall accommodate simultaneous interaction by two users.

4.3 Interface requirements.

- Create a modeless interface.
- Strive for minimal physical effort.
- Provide phonological and semantic cues.
- Keep sentences short and simple
- Provide visual cues.
- Strive for minimal physical effort.

5 Scenarios

Actual or potential user scenarios involving patient, therapist and aphasia researchers, and the relevant methods of interaction are described in the following sub-sections. At the present state of development, PRAXIS can serve clinical and individual activity. Clinical sessions involving the aphasic user and therapist can be conducted over direct, or local or remote network connections. Where the aphasic user and therapist are not in the same space, voice communication is necessary either through POTS, mobile phone, or VOIP connections. The development of tools for data acquisition and modification by researchers and practitioners will require the integration of server components.

5.1.1 Local connection.

In the simplest configuration, the system uses a single touchscreen display which is shared by patient and therapist (see Figure 7 on page 17). In the second configuration pictured below, two displays running from a single computer are set in clone or mirror mode. The patient is seated at the touchscreen display and RFID reader, while the therapist is seated at a conventional mouse/keyboard-activated display. Patient and therapist can sit opposite each other to establish direct eye contact, or side by side for screen sharing. Figure 22 depicts the layout and seating arrangement, Figure 23 is a view of the computer's peripheral connections. A localhost socket connection has been made to connect RFID reader to the Flash swf file.

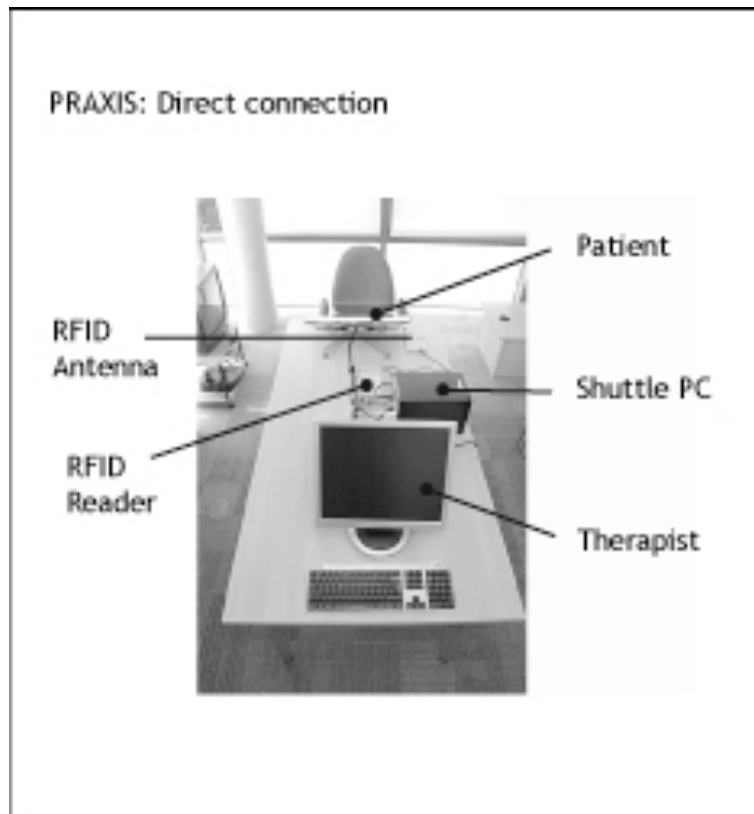

Figure 22: Single computer, 2 displays

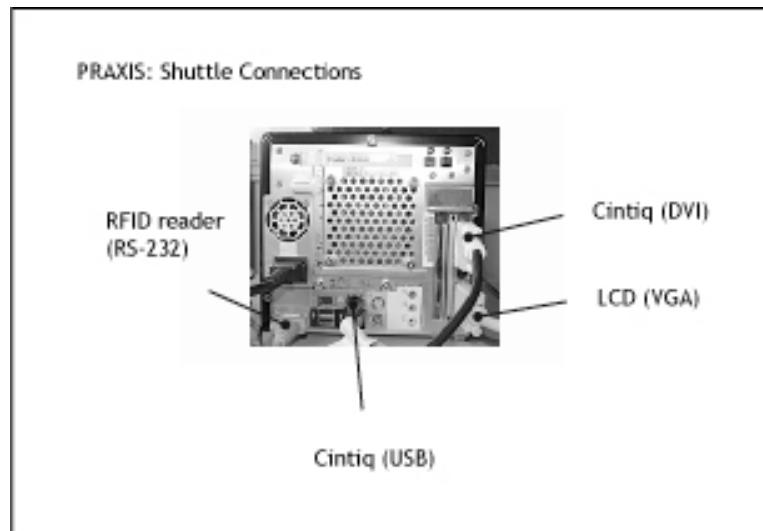

Figure 23: Shuttle connections

5.1.2 Remote

As Flash and TCP/IP are used in the current project, remote client connections are entirely possible. The potential usefulness and implementation of this scenario will require further evaluation by therapist and designer stakeholders. Touchscreen or mouse/keyboard interaction can be readily implemented with an http server, where the swf file is embedded in an html document. The diagram in depicts a continuum of local, intranet, and Internet connections. The diagram is a simplification. It is more likely that content accessed via Internet will reside on a web server, whereas local and intranet connections can be served from a standalone computer.

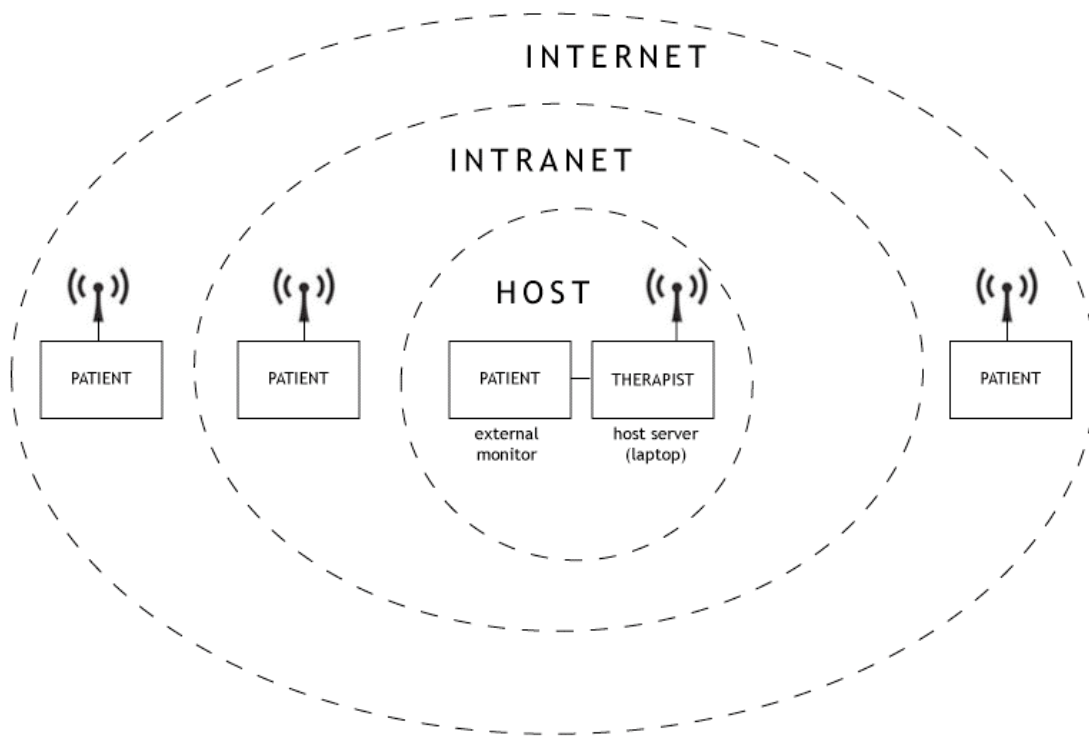

Figure 24: PRAXIS world.

5.1.3 Therapist/ researcher interaction.

The possibility of collaborative research and data sharing, by means of a web-accessible database server is under consideration. In the initial stage (admittedly premature) some work was undertaken to compile both a Standard English lexicon and list of 3,000 frequent usage words. The lexicon was assembled and grepped from the 1918 edition of Webster's Third

International Dictionary.⁵ The Oxford Advanced Learners' Dictionary is a list of 3,000 commonly used English words selected according to a number of criteria.⁶

6 Evaluations

We scheduled two evaluations, the first with an aphasia expert, the second with an expert in interaction design. The first evaluation (videotaped) took place on July 27, 2007 and the second of August 23, 2007 (noted). Observations and suggestions - from the former on user experience, and the latter on usability – influenced design considerations and direction. Evaluations were conducted as an informal mix of heuristics and cognitive walkthrough. (An essential evaluation however, that of the primary user, could not be accomplished due to time and access constraints.) As overlapping issues emerged, they are discussed together and listed below.

Design element	Evaluation 1: therapist	Evaluation 2: designer
Interaction: RFID	Method of interaction unclear Colour coding Extended text-only interaction	Method of interaction unclear Tagging of visual images
Interaction: Pen/display Hardware: Display	Simplification of identification exercise Dissatisfaction with pen display: expressed preference for touch	Hit event cueing

Table 4: Issues emerging from evaluations

The most obvious need that emerged from both evaluations was for improvement in the RFID tag interaction. We made an erroneous assumption about the intuitiveness of this activity. Both participants managed to “mess up” the tag reader by stacking cards on top of each other on the reader. The interaction had been designed to process cards one by one. As it exists at the time of this writing, the interaction is limited by a modal method of interaction that, if not followed, causes a jumble of phrases to appear on the display. Another objective of this exercise, the correct linear arrangement of tag phrases after submitting them to the reader, had not been realised. The challenge here then is both to afford the user more than one way of doing things, and to clarify the linear layout of the tags on the desktop.

⁵ This public domain resource was downloaded, assembled, and grepped from <http://www.gutenberg.net>, an Open Source repository of over 20,000 free books.

⁶ For further information, go to http://www.oup.com/elt/catalogue/teachersites/oald7/oxford_3000/oxford_3000_intro?cc=global

The lack of visual cueing between the image on the display, and the printed tags prompted further thinking about the general nature of speech and impairment. As language is not actually lost in aphasia, effective therapy is the restoration or strengthening of existing neural pathways, or the creation of new ones. But as neural activity in one area triggers activity in other related areas, perhaps we can affect the goal of therapy by Hebbian learning? In other words, in a normal sighted person, the spoken or written word “red” will trigger information stored in visual memory. A proposed method of stimulating language in this way is depicted in Figure . In this scenario, a visual narrative is deconstructed into elements of agent, action and object and printed on RFID tags. These tags, when presented to the reader, trigger the appearance of the corresponding lexical information on the display.

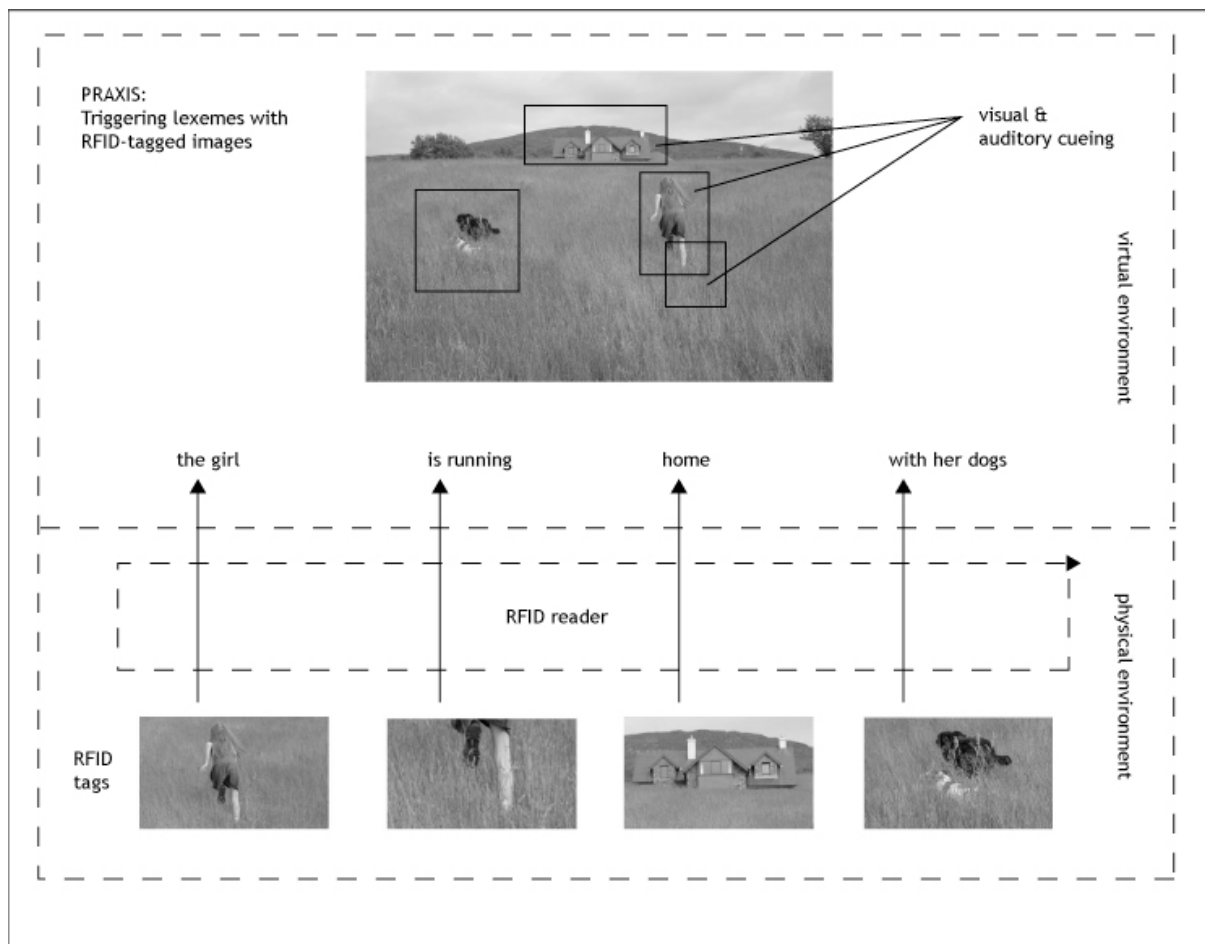

Figure 25: Triggering lexemes with images.

6.1 Conclusions

7 Conclusions, Limitations, Future Work

Conclusions about the efficacy or effectiveness for the primary user of PRAXIS can not yet be determined. The work of this thesis has primarily consisted of the development of the concept, identification of user needs, and design of a system of hardware and software elements that can now be used to test hypotheses and gather data. As a paramount requirement in the user-centred design project is an accurate determination of user needs, there is a frustration in undertaking a project such as this, where the impaired ability of the primary user to communicate needs represents both obstacle and need. I imagine my primary user, in a moment of fluid speech, saying, “If I were able to tell you what I need, I would have no need.” So barring direct communication, one must then proceed from the first evaluations with expert users, to obtain the requisite approval of a regulatory agency, to enlist users in studies, and to collaborate with speech language therapists, gather and analyse results.

The most obvious omission of this project is the lack of speech recognition technology. Time constraints, and the present state of speech recognition technology precluded inclusion of what must certainly feature in the near future as an essential and integral element of language-based computer interaction. I am reminded of the question Bart and Lisa Simpson repeat over and over from the back seat of the family car, “Are we there yet? Are we there yet?” Almost, I think. However, the dysarthria (motor speech disorder) that can result from stroke poses additional, if not insurmountable obstacles. Consideration of this particular problem brings to my mind the “Total Communication” concept (Pound, 2001), which proposes a multimodal approach involving, speech, gesture, drawing, writing, facial expression and the use of props to facilitate communication.

Consideration of the reorientation of PRAXIS as a Total Communication tool led the author to a wider consideration of conceptual models of disability. In contrast to medical and philanthropic models, the social model (upon which this approach is based), disability is a result of the failure of the social and physical environment to adequately provide for the needs of impaired individuals: Should foot fit shoe, or shoe fit foot?

Another shortcoming of the work is the absence of administrative controls for a therapist-

administrator. Ideally, we will at some point in the future possess an administrative interface where speech therapy exercises can be customised for individual patients. If the program data are available from a database server, we can provide universal access and collaborate within and across networks to acquire data and refine PRAXIS.

References

- Arnold, L. (1999), *The Source for Aphasia Therapy*, Illinois: LinguSystems. ‡
- Bear, M., Connors, B., Paradiso, M. (2007), 'Attention' in *Neuroscience* 3rd ed., Baltimore: Lippincott, Williams & Wilkins, 643-658.
- Caplan, D. (1987), *Neurolinguistics and linguistic aphasiology*, Cambridge University Press.
- Code, C. (1991), 'Symptoms, Syndroms, Models: The Nature of Aphasia' in Code, C. ed., *The Characteristics of Aphasia*, 2nd ed., Sussex: Taylor & Francis, 1-22.
- Cowan, N. (2001), 'The magical number 4 in short-term memory: A reconsideration of mental storage capacity', *Behavioral and Brain Sciences*, 24:1, 87-114.
- Davis, A. ed. (2000), *Aphasiology*, Boston: Allyn & Bacon.
- De Bruijn, D., De Mal, S., Van Oostendoorp, H. (1992) 'The influence of screen size and text layout on the study' *Behaviour & Information Technology*, 11:2, 71-78, available: <http://www.informaworld.com/smpp/title~content=t713736316>.
- Fink, R., Brecher, A., Schwartz, M. and Robey, R. (2002), 'A computer-implemented protocol for treatment of naming disorders: Evaluation of clinician-guided and partially self-guided instruction', *Aphasiology*, 16:10, 1061–1086, available: <http://dx.doi.org/10.1080/02687030244000400>.
- Fostervold, K. (2001), 'VDU work with downward gaze: the emperor's new clothes or scientifically sound?', *International Journal of Industrial Ergonomics*, 31 (2003), 161-167, available: <http://www.sciencedirect.com>.
- Fostervold, K., Aara, A. and Liec, I. (2005), 'Work with visual display units: Long-term health effects of high and downward line-of-sight in ordinary office environments', *International Journal of Industrial Ergonomics*, 36 (May), 331-343, available: <http://www.sciencedirect.com>.
- Hebb, D. (1949), *Organization of Behavior*, New York: Wiley.
- Heuer, H., Brüwer, M., Römer, T., Kröger, H. and Knapp, H. (1991) 'Preferred vertical gaze direction and observation distance', *Ergonomics*, 34:3, 379–392, available: <http://dx.doi.org/10.1080/00140139108967321>.
- Howard, D. (1994), 'The Treatment of Acquired Aphasia', *Philosophical Transactions: Biological Sciences*, 346(1315), The Acquisition and Dissolution of Language. (Oct. 29, 1994), 113-120, available: <http://www.jstor.org>.
- Irish Medical News (2001), *Rehabilitation Hospital Under Severe Strain*, [online], available: <http://www.irishmedicalnews.ie/articles.asp?Category=feature&ArticleID=19227> [accessed 18 August 18, 2007].
- Ishii, H., Ullmer, B. (1997), 'Tangible Bits: Towards Seamless Interfaces between People, Bits and Atoms', *Proceedings of CHI '97*, ACM (March 22-27).
- James, W. (1890), 'Attention' in *The Principles of Psychology*, [online], available: <http://psychclassics.yorku.ca/James/Principles/index.htm>, [accessed August 18, 2007].
- Jaschinski, W., Heuer, H., and Hannegert, K. (1998) 'Preferred position of visual displays relative to the eyes: a field study of visual strain and individual differences',

- Ergonomics*, 41:7, 1034–1049, available: DOI: 10.1080/001401398186586.
- Katz, R. (2002), 'Aphasia Treatment and Computer Technology' in Code, C. and Müller, D. eds., *Treatment of Aphasia: From Theory to Practice*, London: Whurr, 253-285.
- Keates, S. and Robinson, P. (1999) 'Gestures and multimodal input', *Behaviour & Information Technology*, 18:1, 36–44 available: DOI: 10.1080/014492999119237
- Landt, J. (2001), *The Shrouds of Time: The History of RFID*, [online], available: http://www.aimglobal.org/technologies/rfid/resources/shrouds_of_time.pdf, [accessed August 18, 2007].
- Lapointe, Leonard L. and Erickson, Robert J. (1991) 'Auditory vigilance during divided task attention in aphasic individuals', *Aphasiology*, 5:6, 511-520, available: <http://dx.doi.org/10.1080/02687039108248556>.
- Leydon, K. (2004), Design of Vibrotactile Gradients for Guiding the Manual Motion of an RFID-Enabled Hand-Held Locator towards Sought Items in Shelf-Sized Spaces, unpublished thesis (M.Sc.), University of Limerick.
- Morrison, S. (2001), *Phonology Resource Pack for Adult Aphasia*, Oxon: Speechmark. ‡
- Pound, C, Byng, S and Parr, S (2001) Beyond Aphasia: therapies for living with communication disability. Oxon:Speechmark
- Preece, J., Rogers, Y. Sharp, H. (2002), *Interaction Design*, New York: John Wiley & Sons.
- Randall R. (2002) 'A computer-implemented protocol for treatment of naming disorders: Evaluation of clinician-guided and partially self-guided instruction', *Aphasiology*, 16:10, 1061 – 1086, available: <http://dx.doi.org/10.1080/02687030544000155>.
- Robey, Randall R. and Schultz, Martin C. (1998) 'A model for conducting clinical-outcome research: An adaptation of the standard protocol for use in aphasiology', *Aphasiology*, 12:9, 787 – 810, available: <http://dx.doi.org/10.1080/02687039808249573>.
- Rombough, R., Howse, E., Bartfay, W. (2006), 'Caregiver Strain and Caregiver Burden of Primary Caregivers of Stroke Survivors with and without Aphasia', *Rehabilitation Nursing*, 31:5, available: <http://www.rehabnurse.org/education/RNC-260.pdf>.
- Sears, A. and Shneiderman, B. (1991), 'High Precision Touchscreens: Design Strategies and Comparisons with a Mouse', *International Journal of Man-Machine Studies* 34:4, 593-613
- Stockman, H. (1948), 'Communication by Means of Reflected Power', *Proceedings of the Institute of Radio Engineers*, 36:10, 1196-1204, available <http://ieeexplore.ieee.org>.
- Tan, D. (2004), 'Exploiting the Cognitive and Social Benefits of Physically Large Displays', unpublished thesis (D.Phil.), Carnegie Mellon University.
- Vallier, F. (1995), *Reading Workbook for Aphasia*, Youngtown, AZ: ECL Publications. ‡
- Wolf, C. (1992), 'A comparative study of gestural, keyboard, and mouse interfaces', *Behaviour & Information Technology*, 11:1, 13–23 available: DOI:10.1080/01449299208924315.
- Ziegler, J. and Fähnreich, K. (1988), 'Direct Manipulation' in Helander, M. ed. in *Handbook of Human-Computer Interaction*, Amsterdam: Elsevier, 123-133.